



PROPERTY OF THE

★ Shelf No.

40671



From the Bates Fund.



TRAITÉ COMPLET
DE
LA PEINTURE,

TRAITÉ COMPLET

DE

LA PEINTURE,

PAR M. P^{***} DE MONTABERT.

—•••—
FIGURES EXPLICATIVES.
—•••—

PARIS,

CHEZ BOSSANGE PÈRE,
LIBRAIRE DE S. A. R. M^{gr} LE DUC D'ORLÉANS,
RUE DE RICHELIEU, N° 60.

1829.

•••••
•••••
•••••
•••••
•••••

4067.1

6656

Bl. L.

Jan. 6, 1862

53596

UNIVERSITY OF CHICAGO
LIBRARY
53596



Gravé par.

Publié par

Dessiné à Rome, en 1827, par Jean CILAVELLE, de Paris, n° 7.

HERCULE.

Statue en marbre de Paros, haute de 5 pieds 6 pouces, trouvée à Velletri en 1820.





Digitized by the Internet Archive
in 2011 with funding from
Boston Public Library



4.



5.

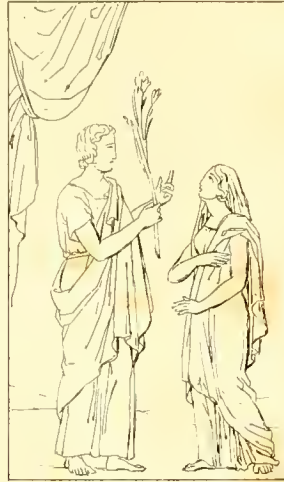

6.



8.



10.



9.



11.



7.



Gravé par M. Peronard.





12.



13.



14.



15.



16.



18.



17.



19.



20.



21.

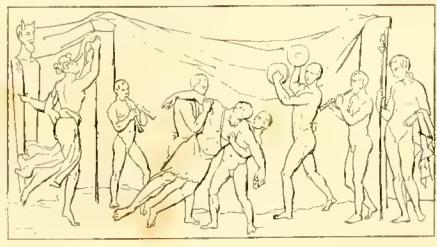

Gravé par M. Peronard.



22.



23.



24.



25.



26.



27.



28.



29.



30.



Gravé par M. Peronard.





31.



32.

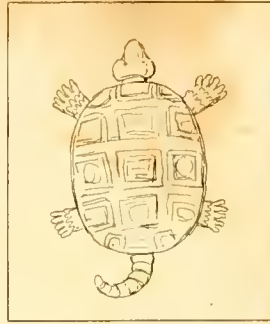

55.



36.

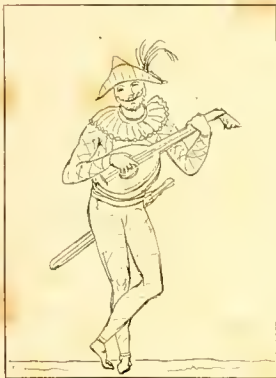

54.



55.



37.



38.



39.



40.



41.



42.



45.



Gravé par M. Peronard.





46.

49.

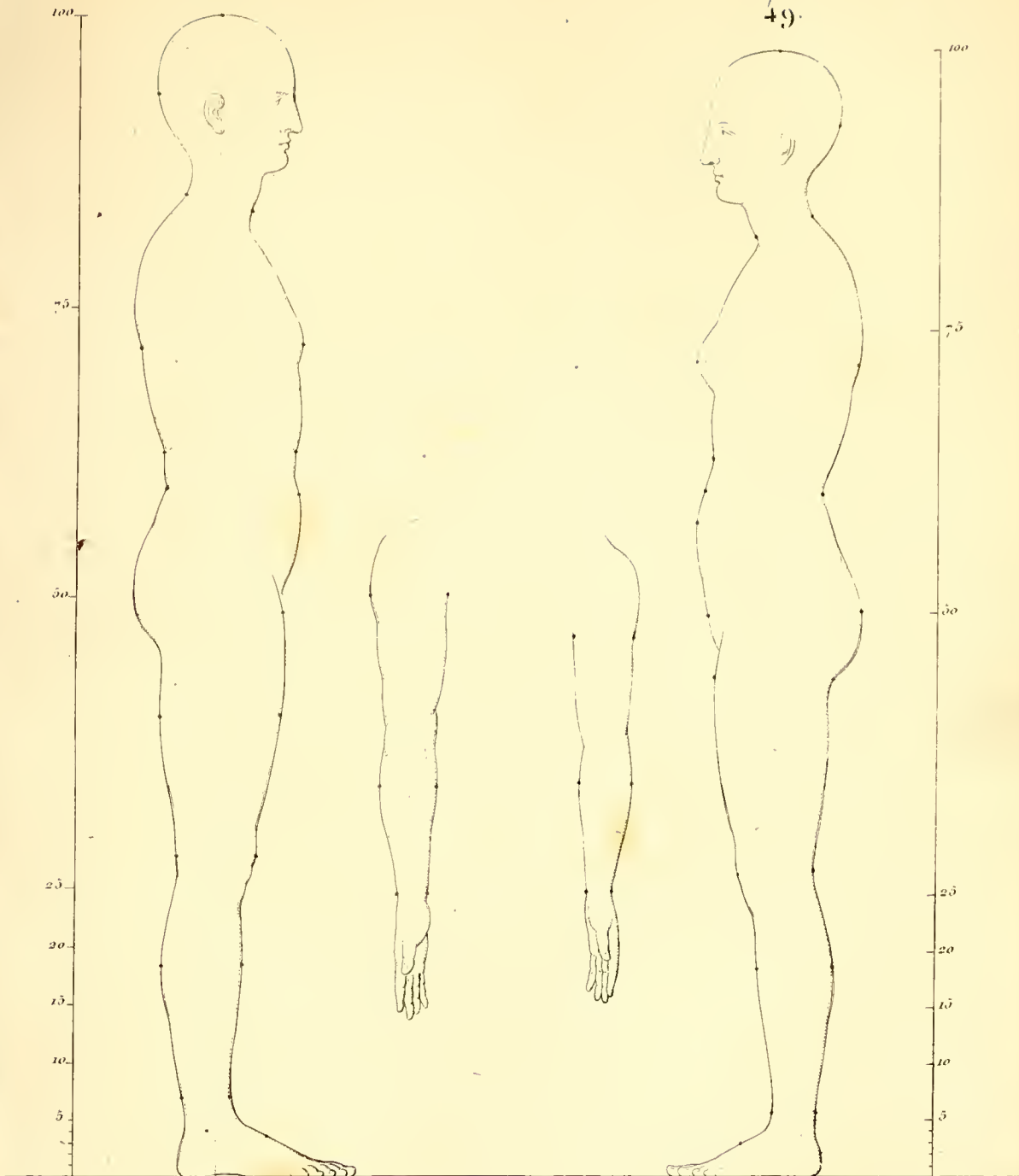



50.

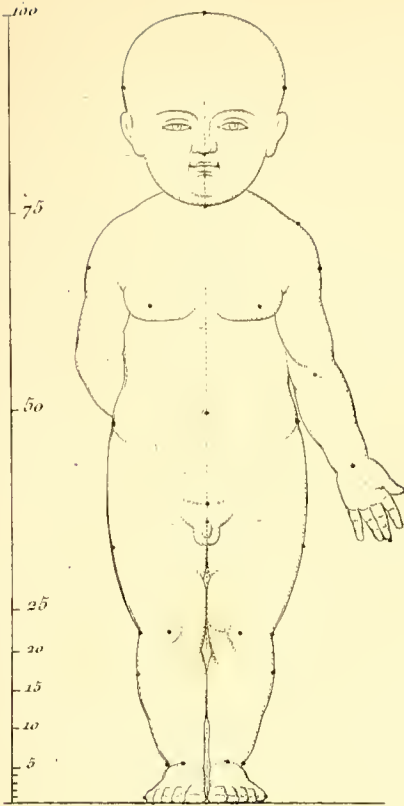

52.

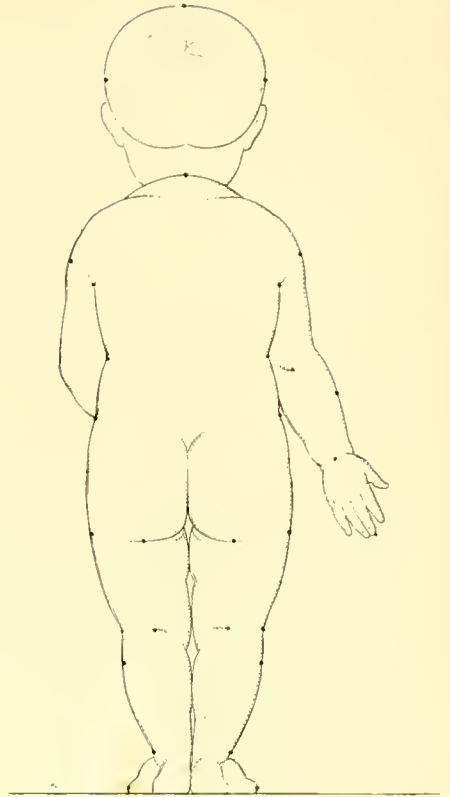

51.

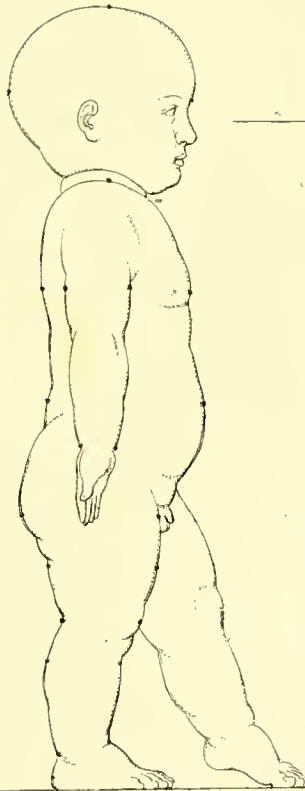

55.

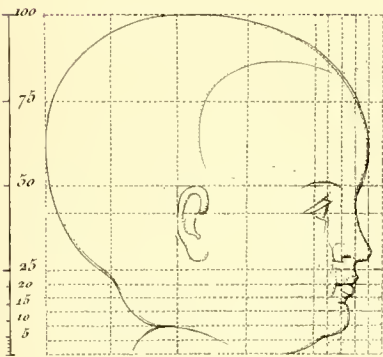

54.

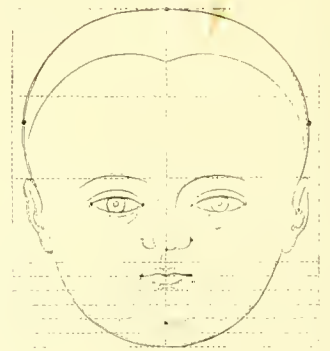

55.

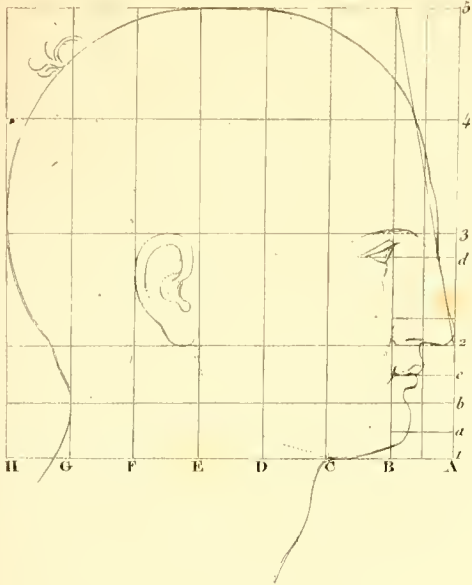

56.

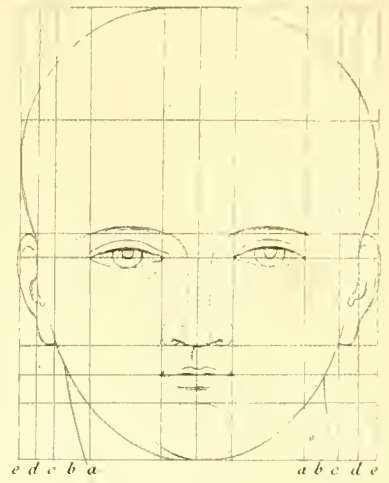

57.

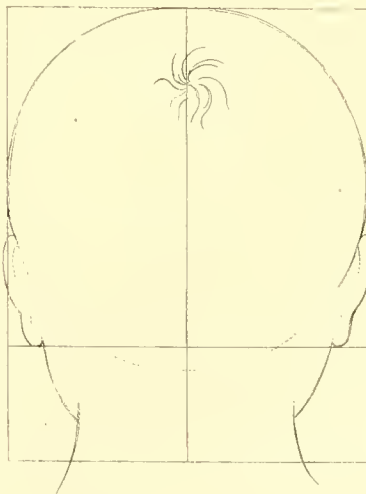

58.

59.

60.



61.

62.

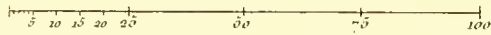
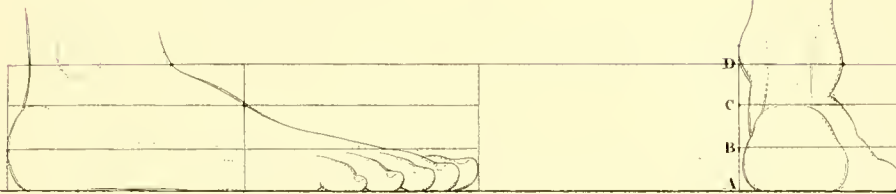

65.

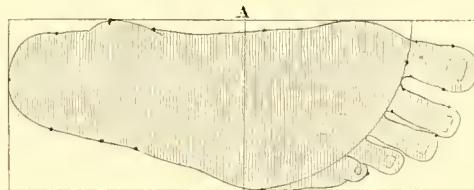

64.

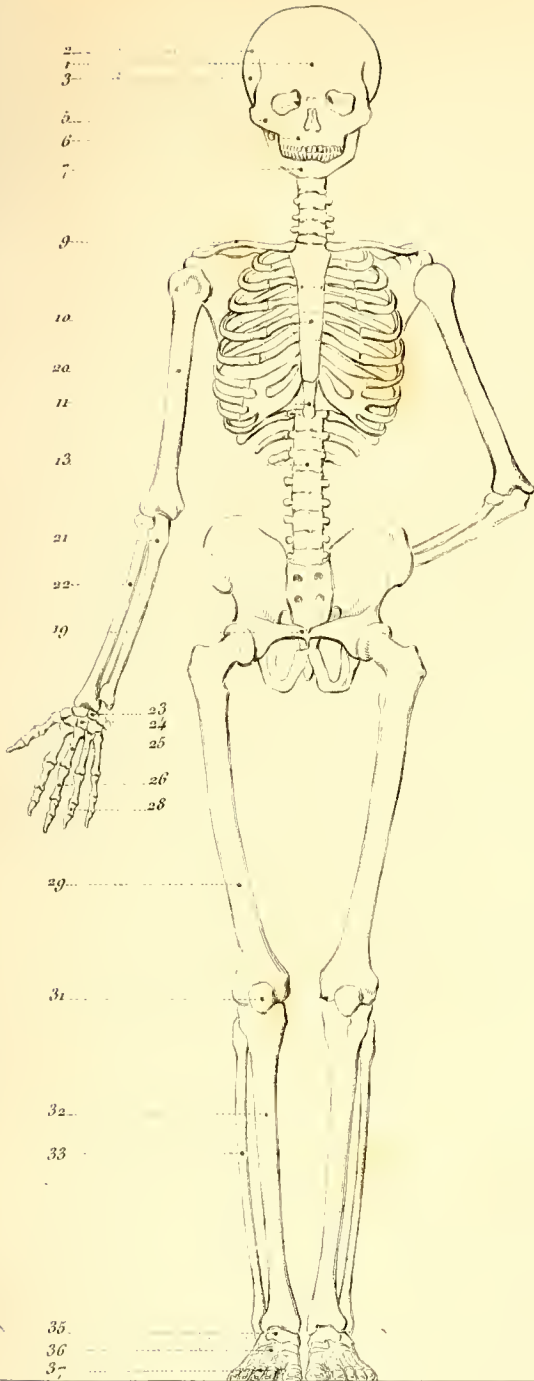

65.

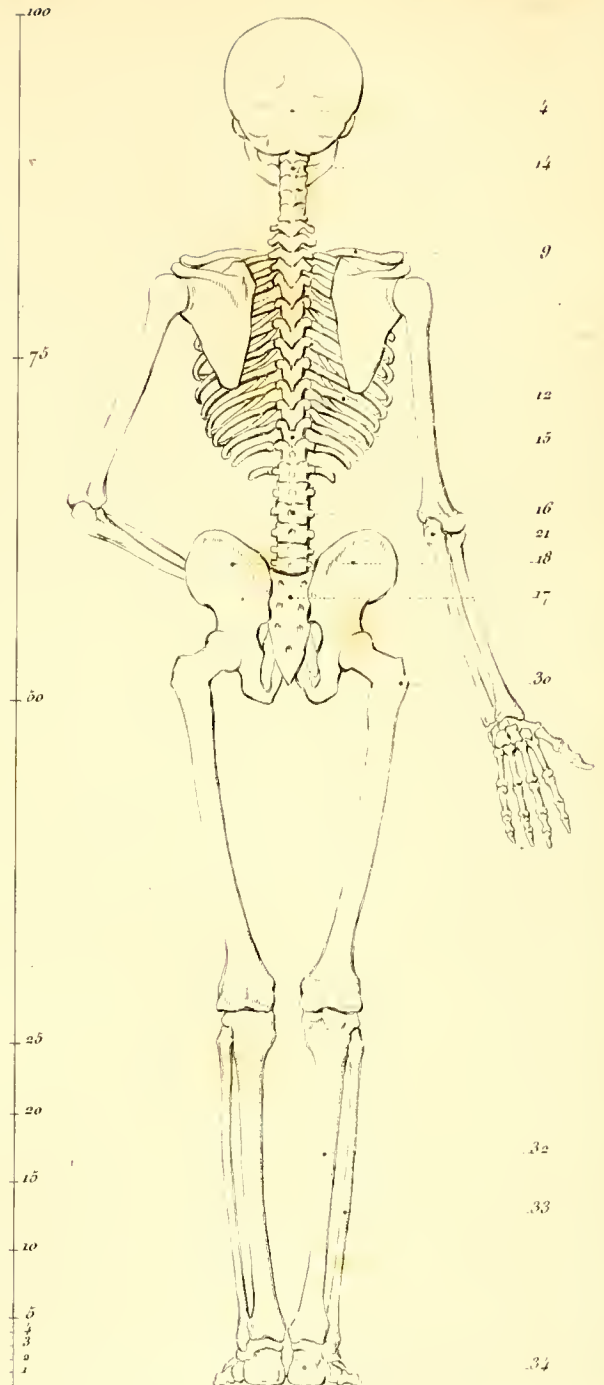



66.

69.

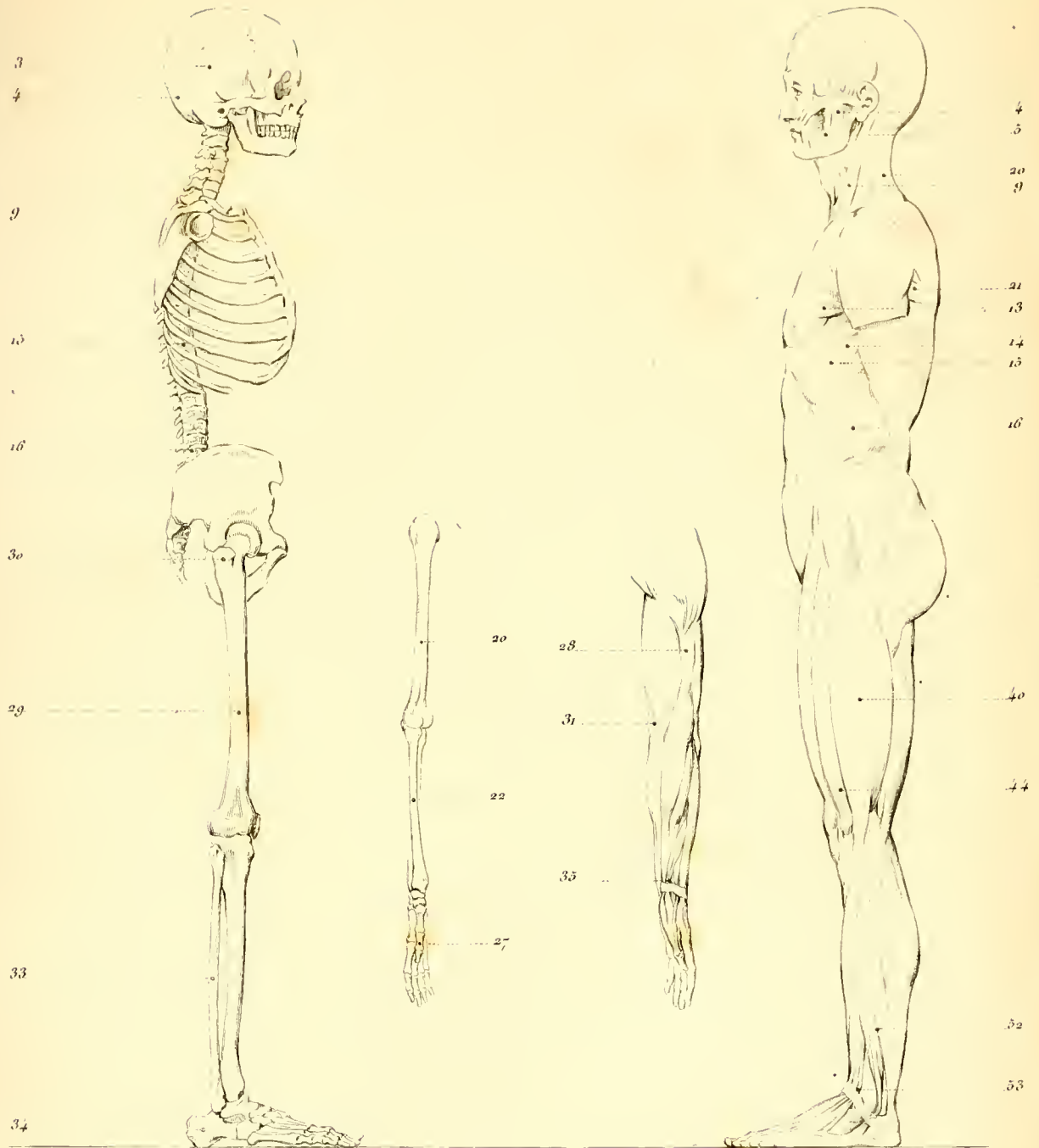



67.

68.

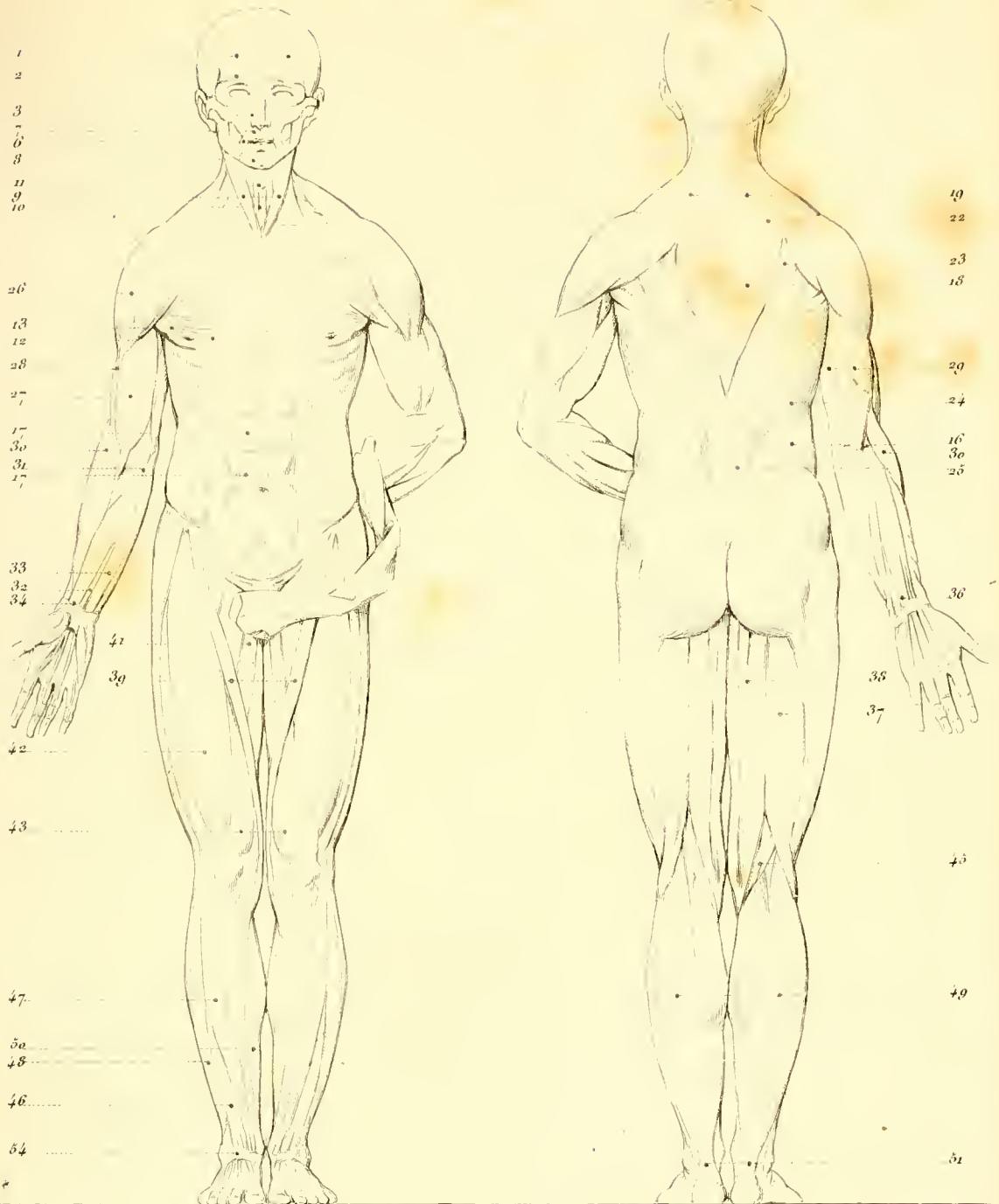

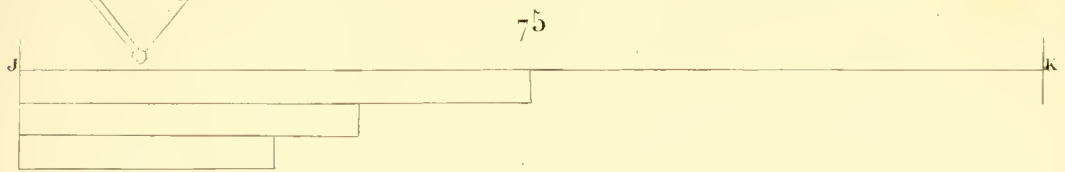
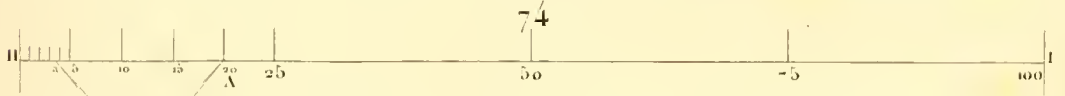
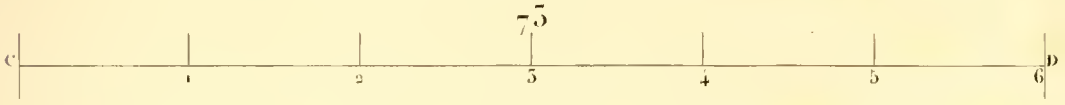
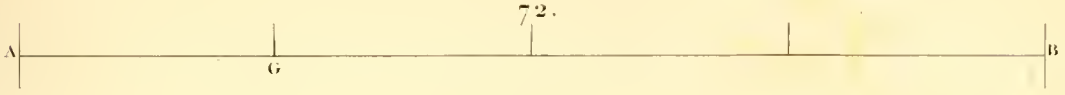
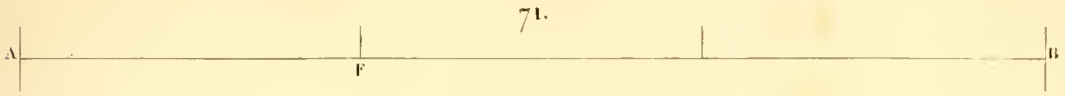
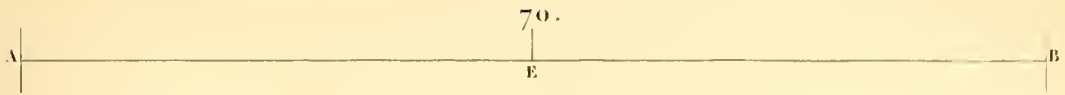

Vol. 6. Chapitre 250. Page 107.

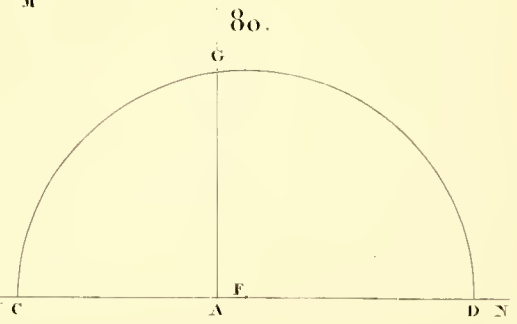
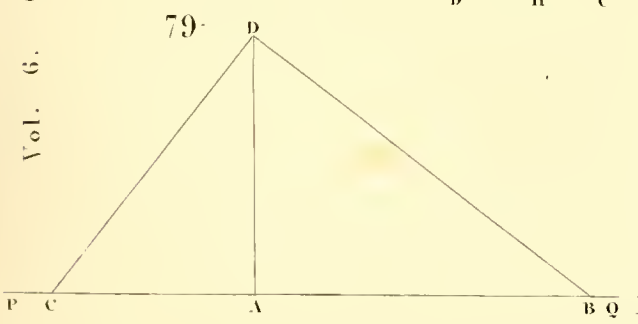
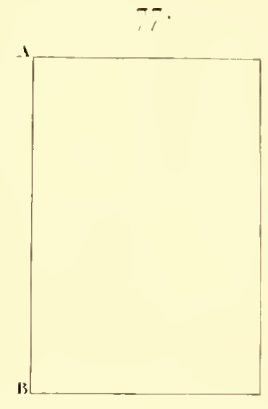
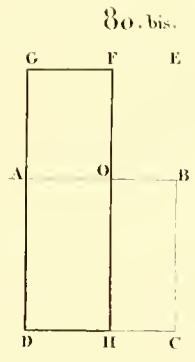
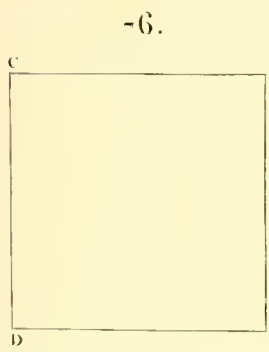

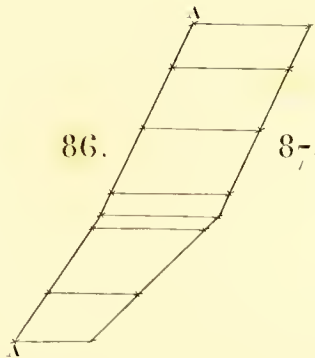
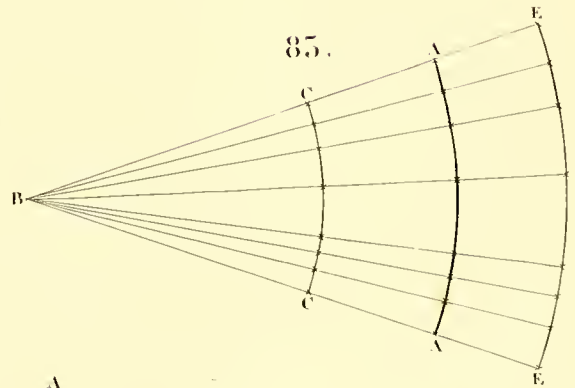
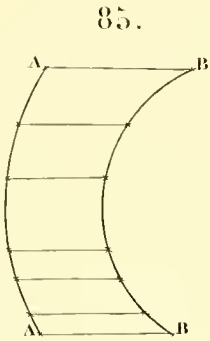
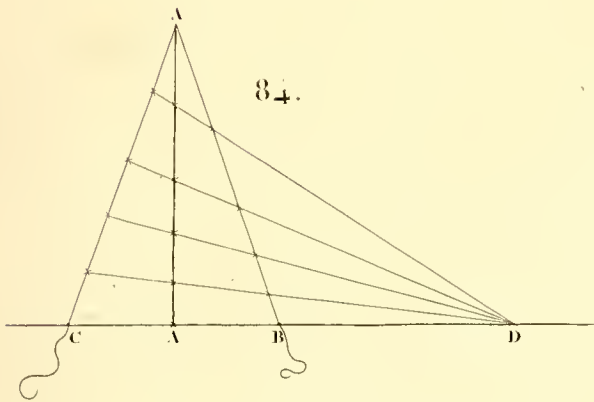
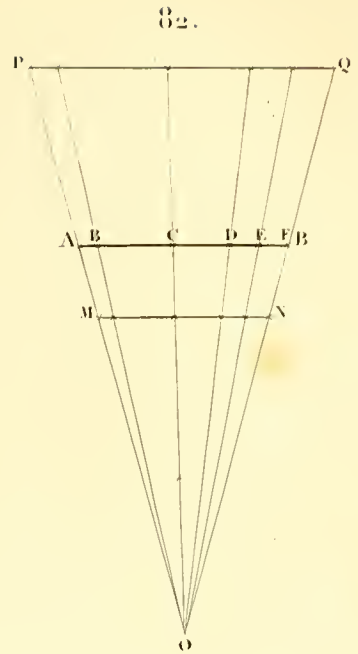
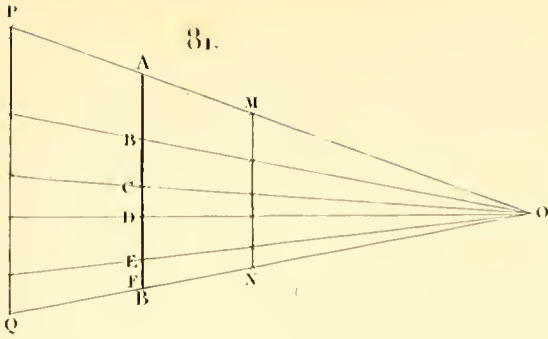

89.

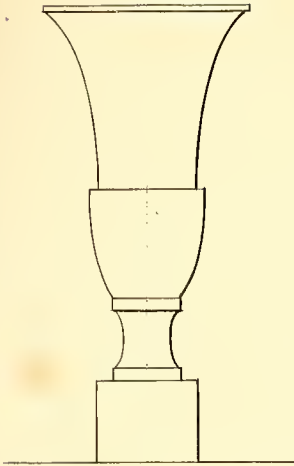

88.

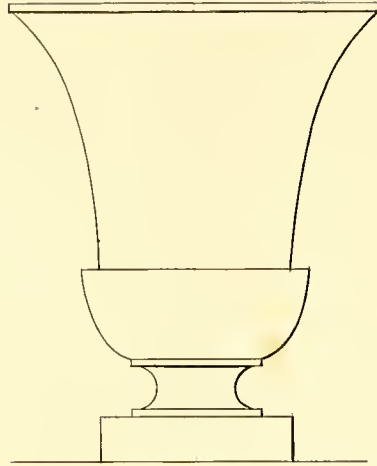

90.

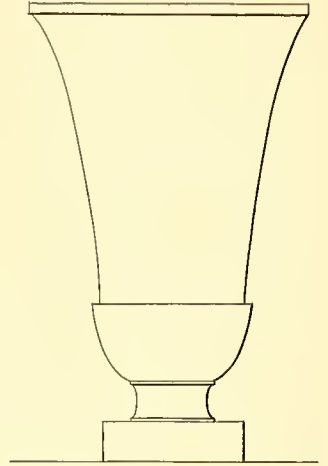

92.

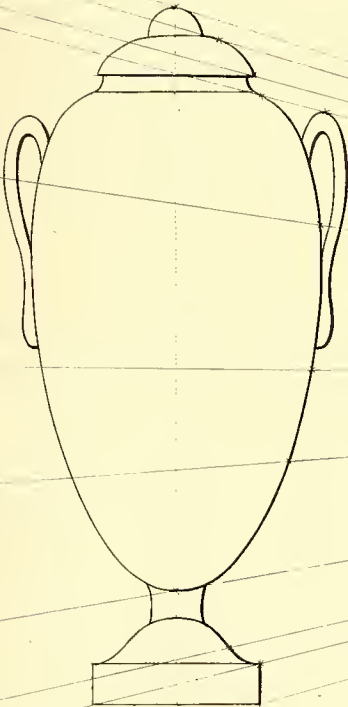

91.

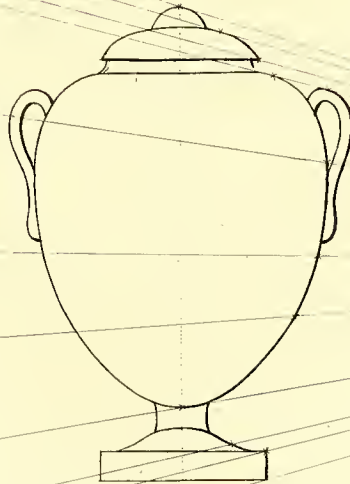

95.

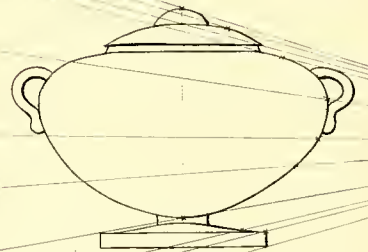

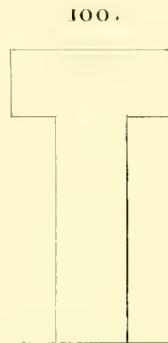
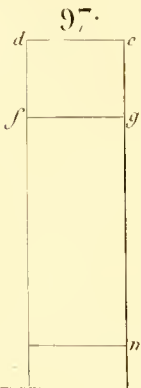
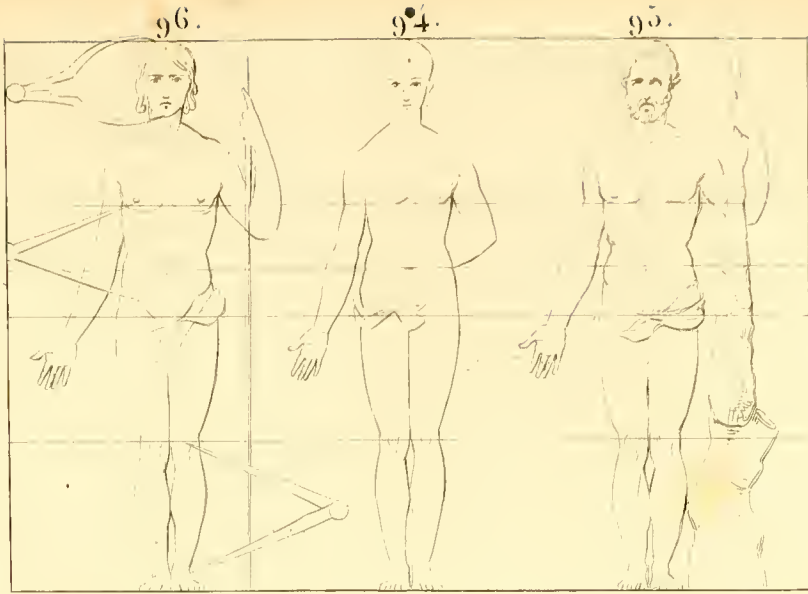



102.

Individu.



103.

Embellissement.



Enlaidissement.



104.

105.

106.

107.

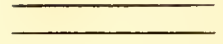
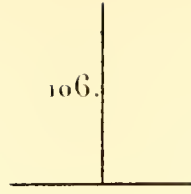

108.

109.

110.

111.

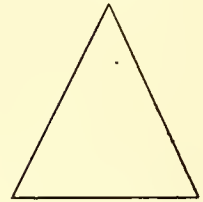
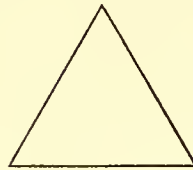
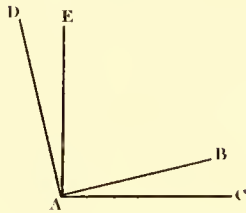

112.

113.

114.

115.

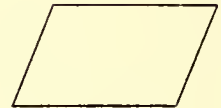
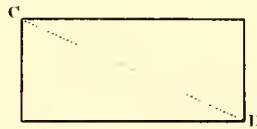
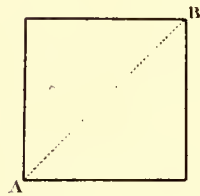
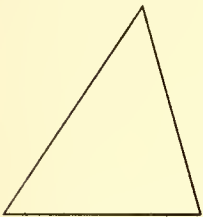

116.

117.

118.

119.

120.

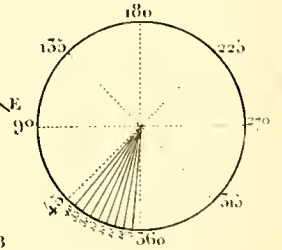
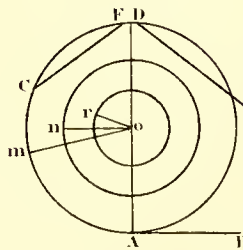
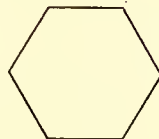
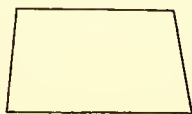
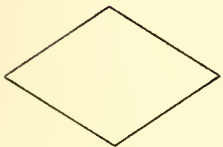



121.

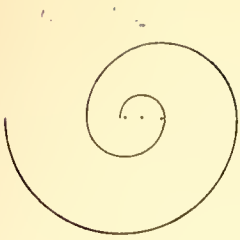

122.

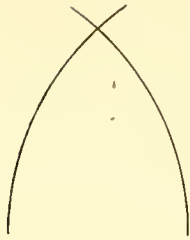

123.

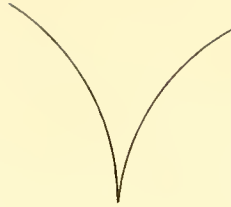

124.



125.

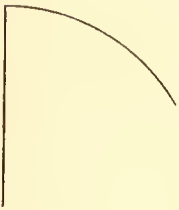

126.

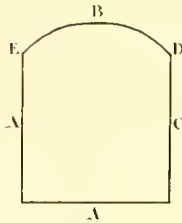

127.

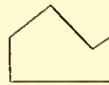

128.

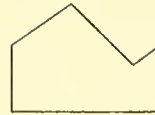

129.

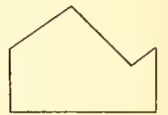

130.

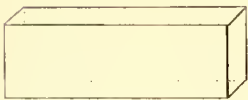

131.

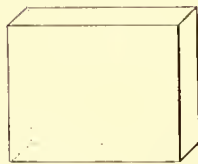

132.

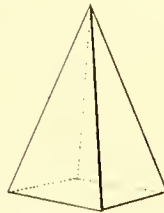

133.

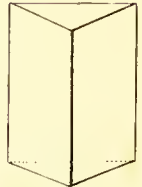

134.



135.

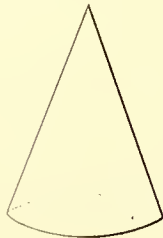

136.

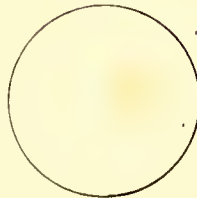

137.

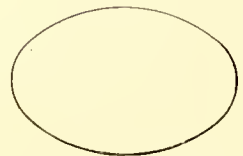

158.

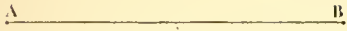

159.

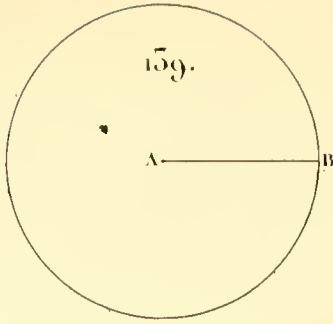

140.

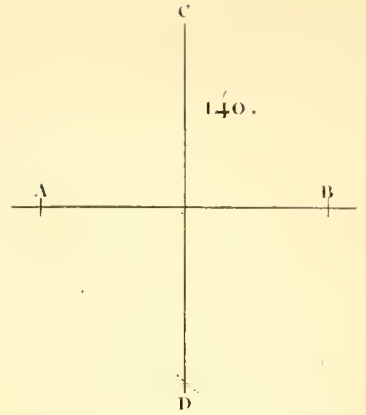

141.

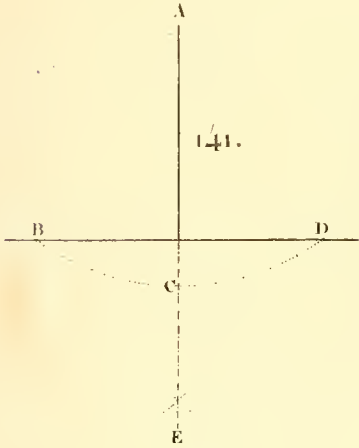

142.

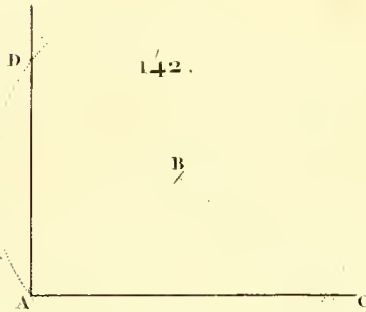

145.

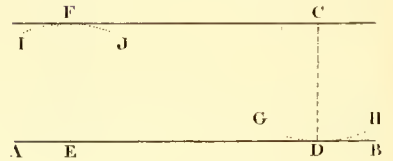

144.

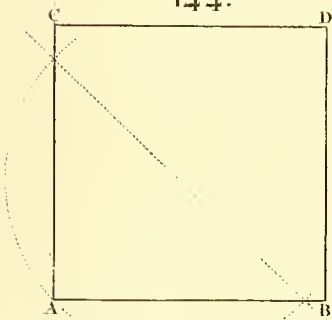

145.

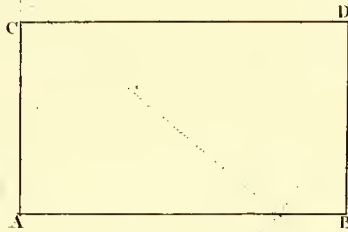

146.

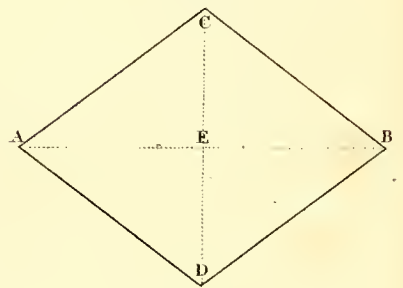

147.

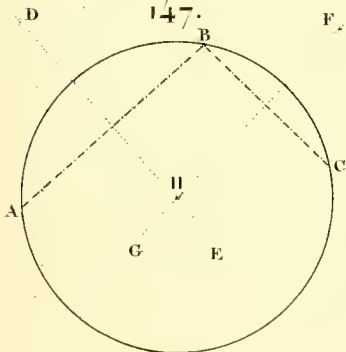

148.

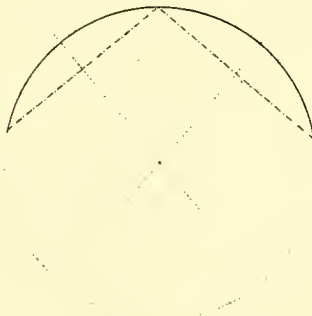

149.

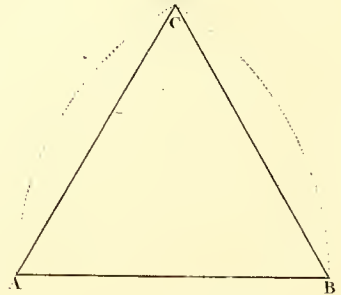

150.

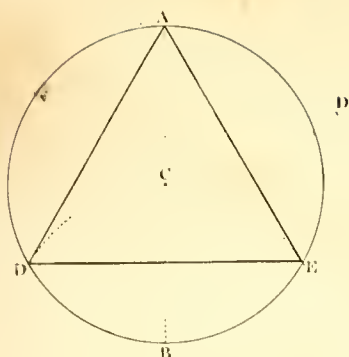

151.

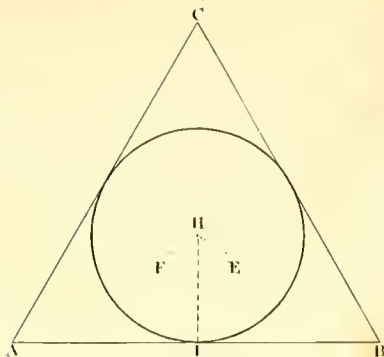

152.

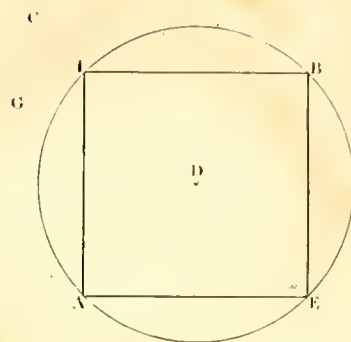

153.

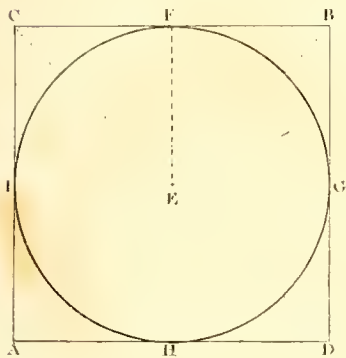

154.

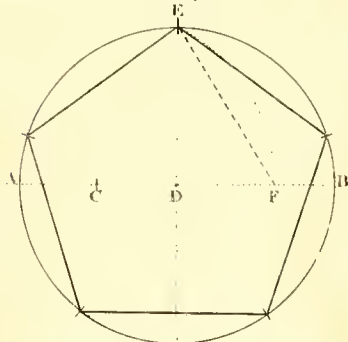

155.

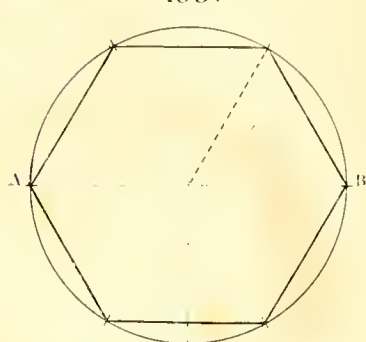

156.

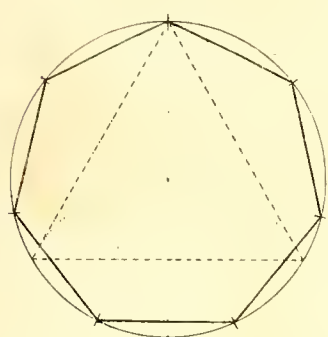

157.

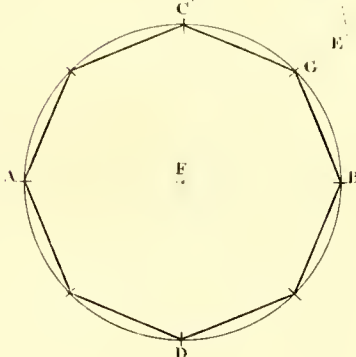

158.

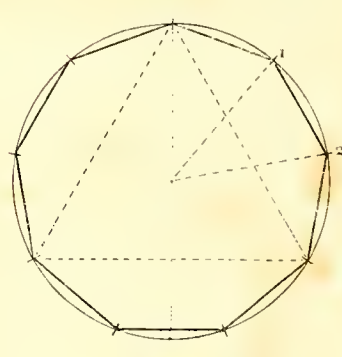

159.

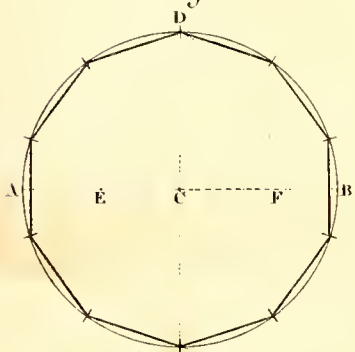

160.

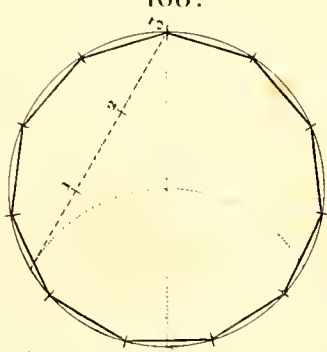

161.

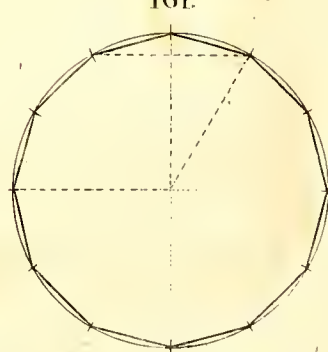



153. bis.

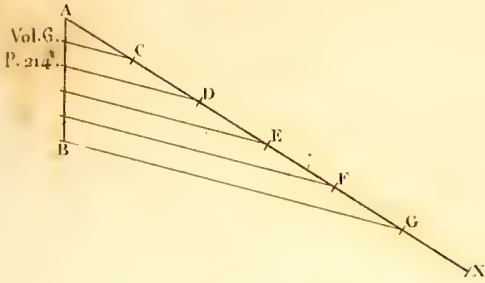

162.

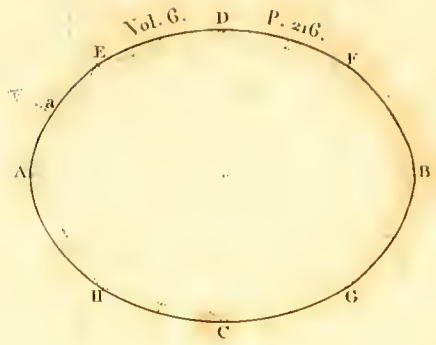

165.

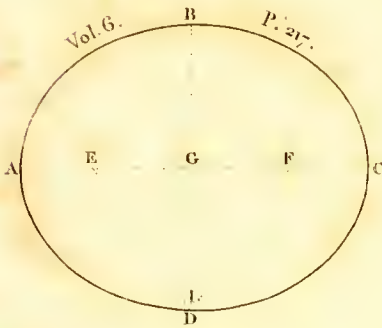

164.

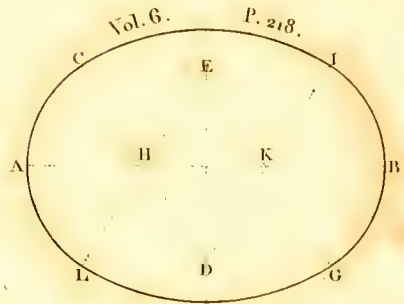

165.

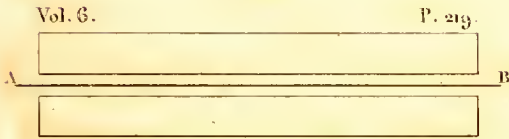

167.

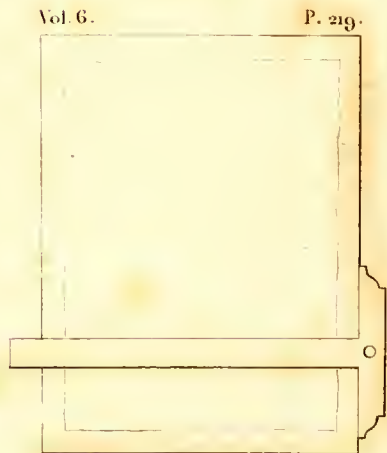

166.

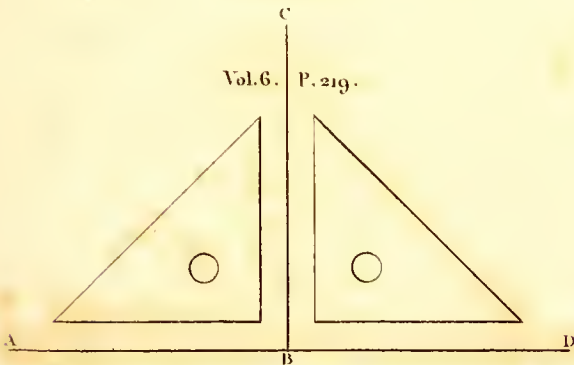



168.



169.



174.

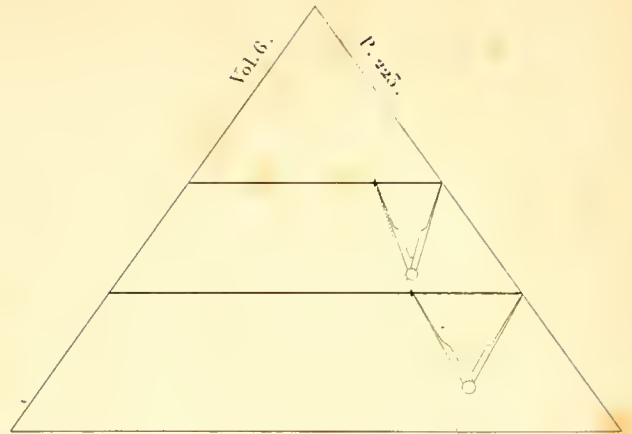

172.

170. Vol. 6. P. 220.

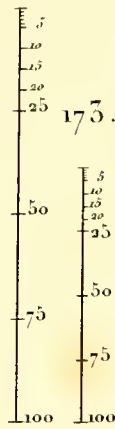
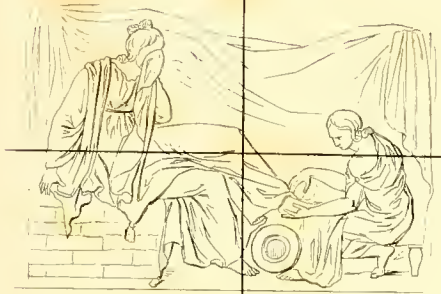

171.

Vol. 6. P. 220.

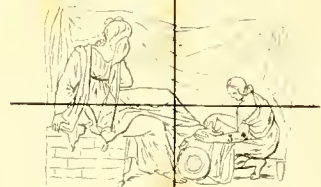

188.

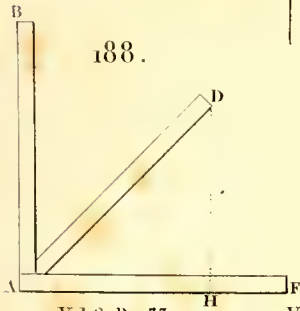

Vol. 6. P. 235.

Vol. 6.

190.

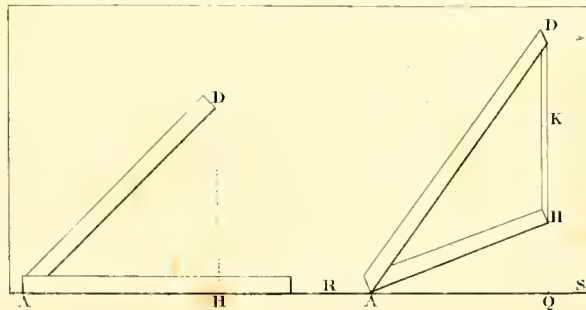

P. 237.

Vol. 6. P. 255.

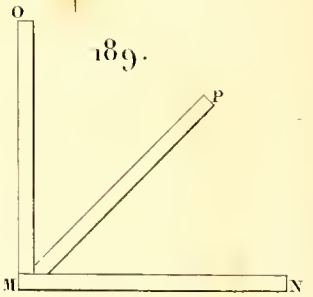

189.



175.

Vol. 6. P. 229.

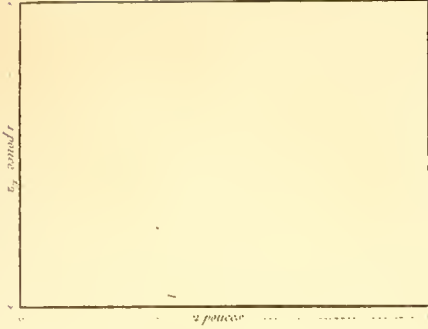

176.

Vol. 6. P. 229.

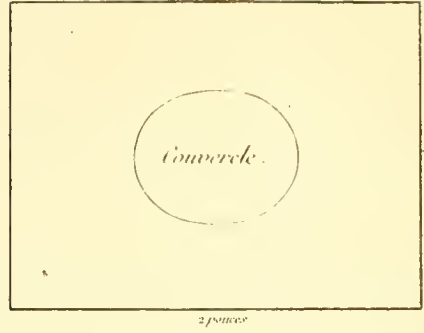

177.

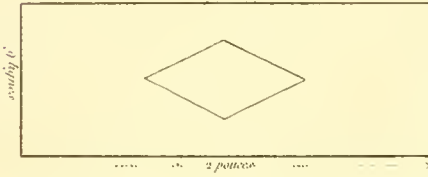

179.

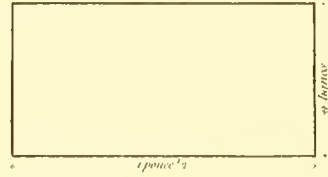

178.



179.

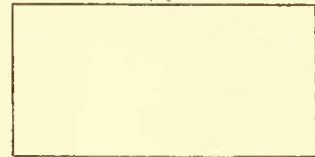

Vol. 6.

191.

P. 240.

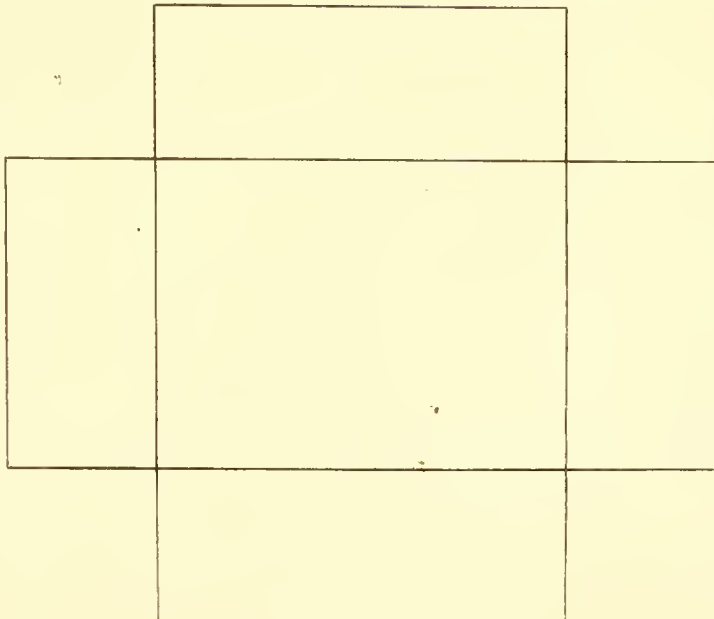

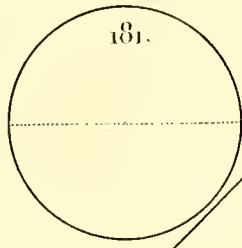
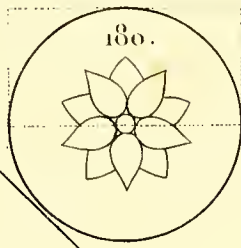
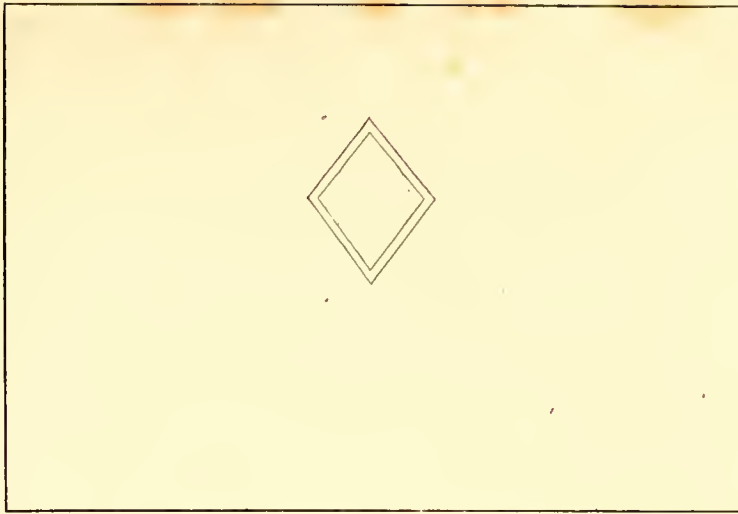

192.

Vol. 6.

P. 241.

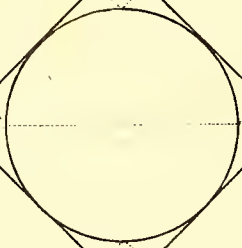

(192. bis.)

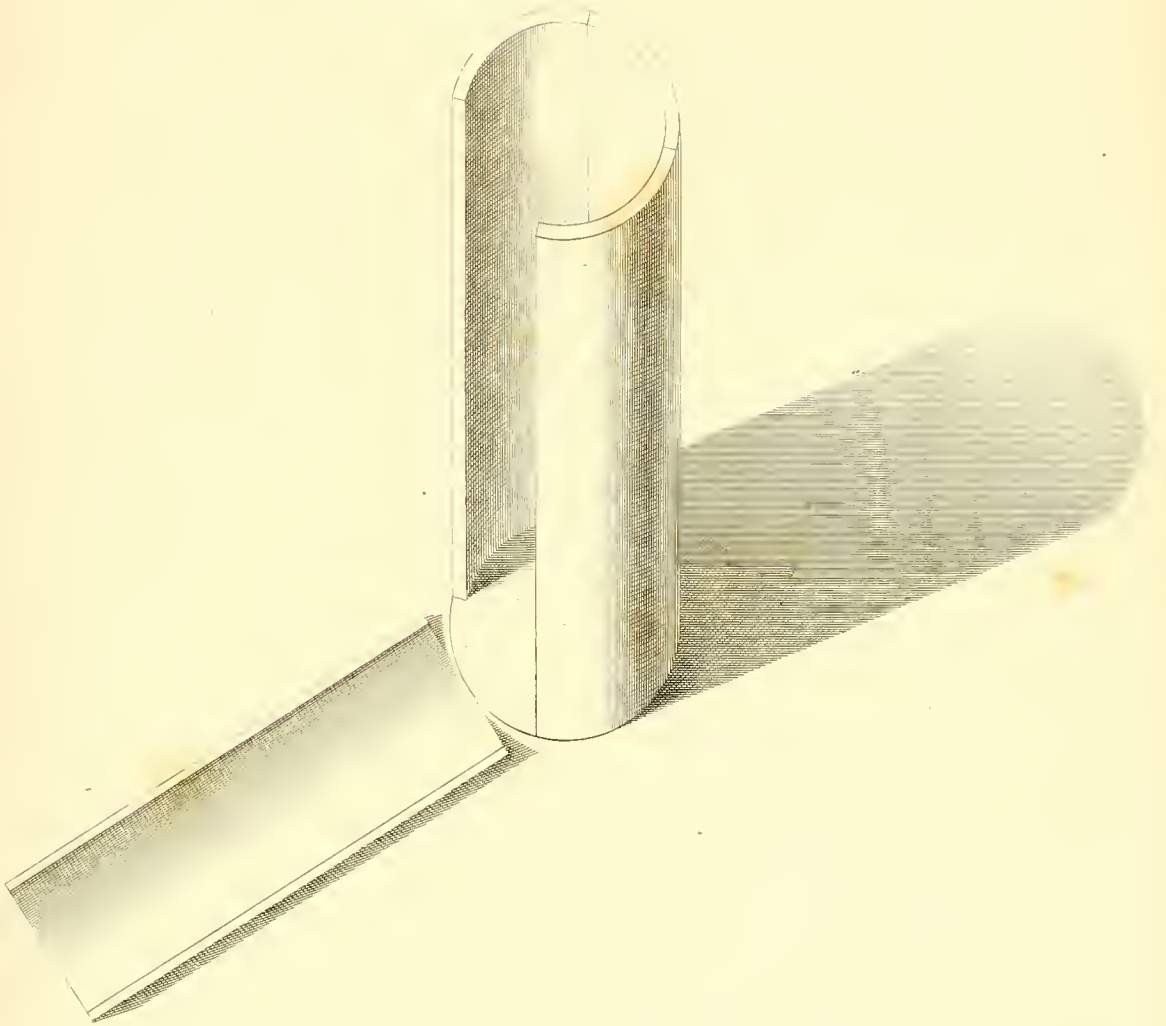

184.

185.

Vol. 6. P. 250.

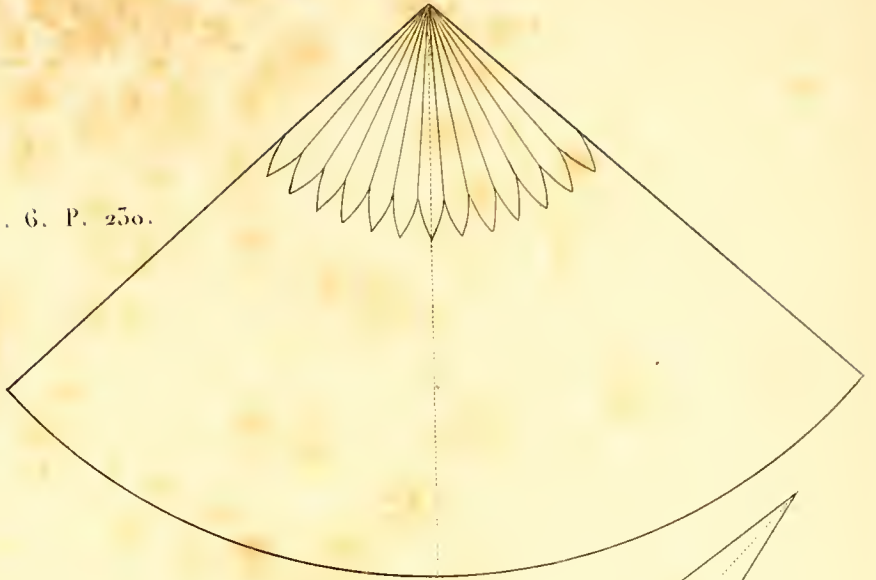
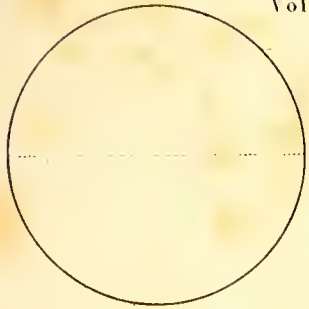

195.

Vol. 6.

P. 241.

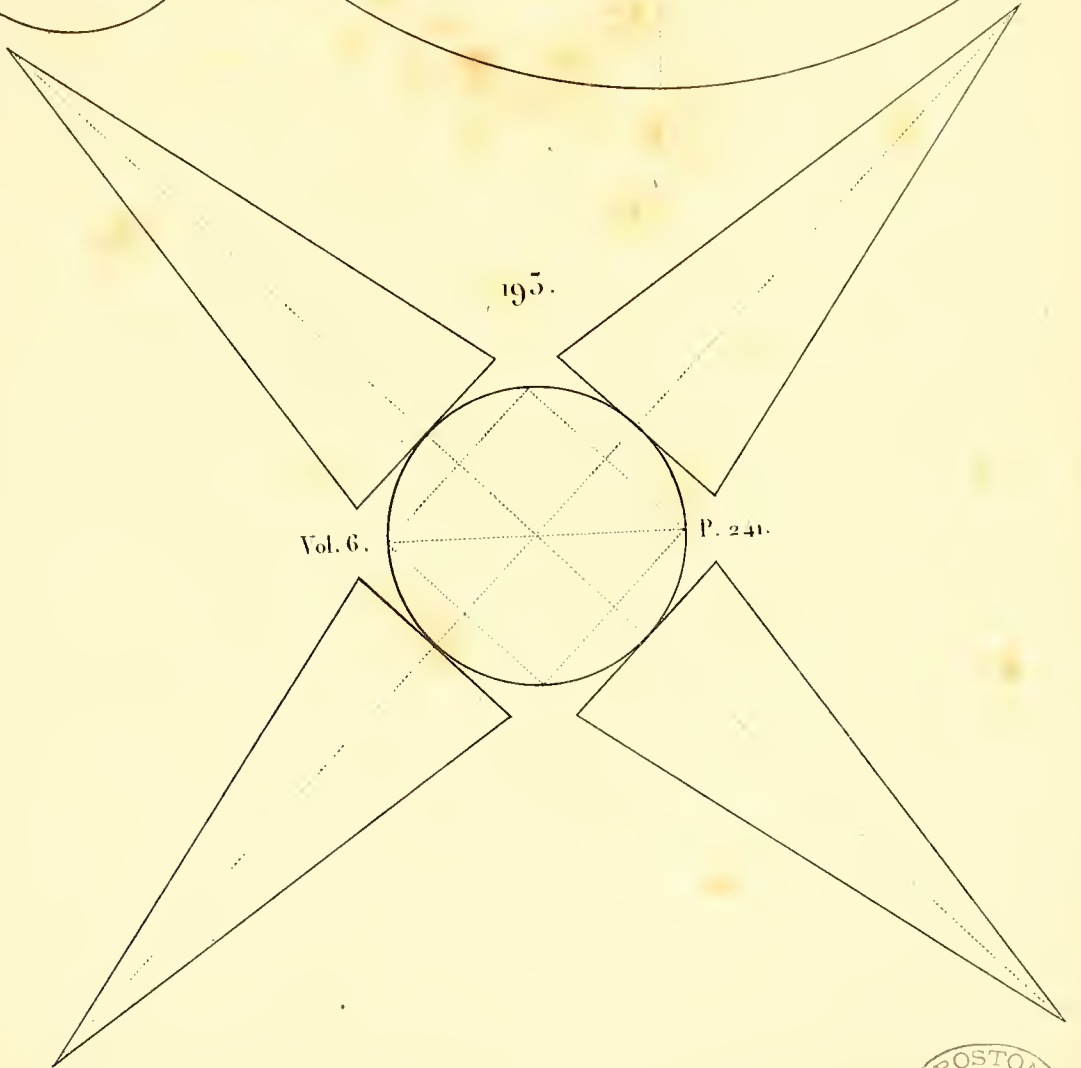

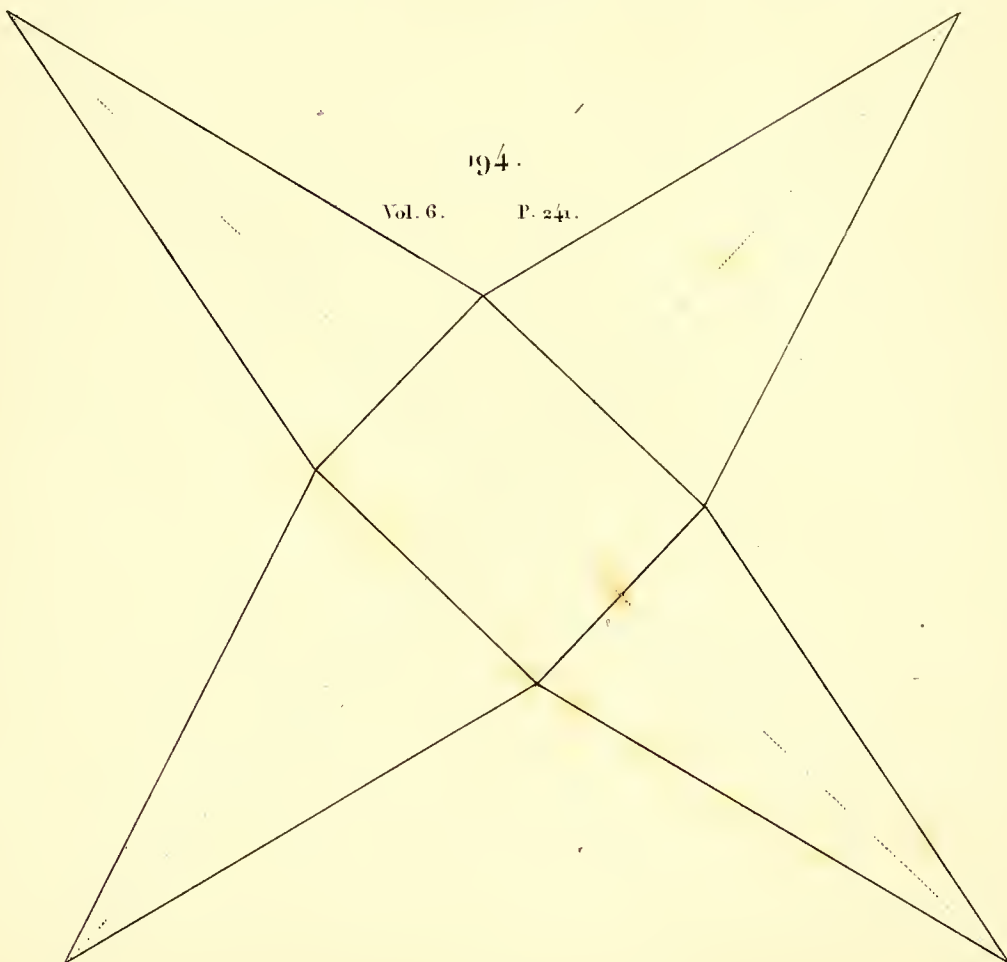
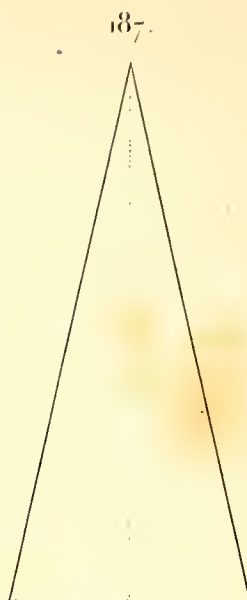
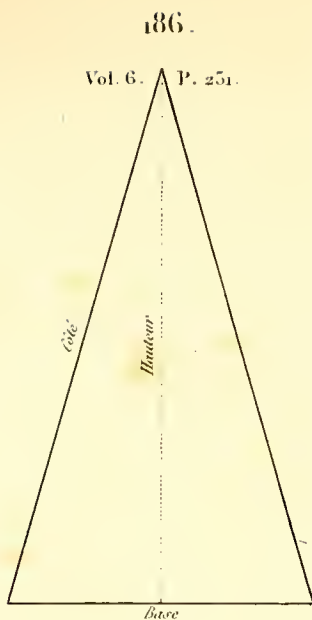
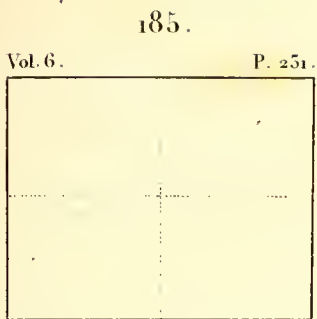

195.

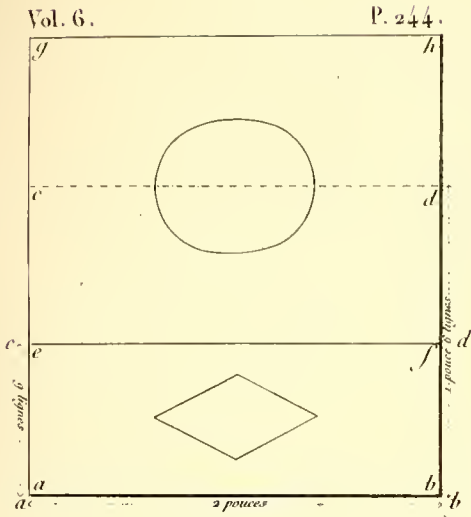

196. Vol. 6. P. 246.

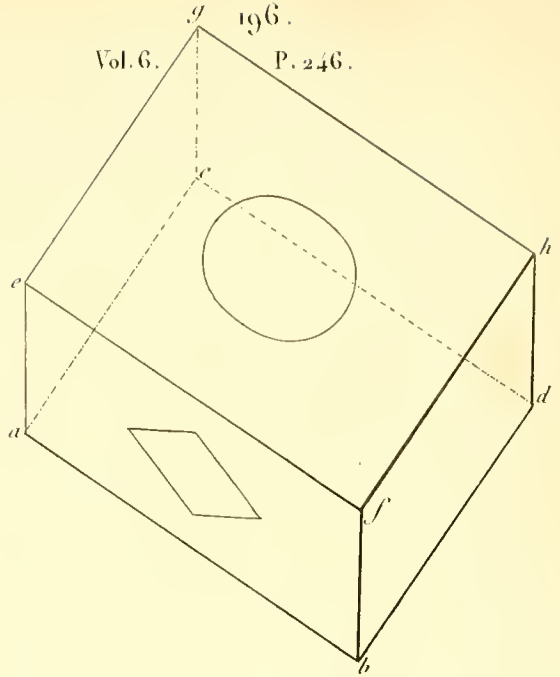

197.

Vol. 6. P. 247.

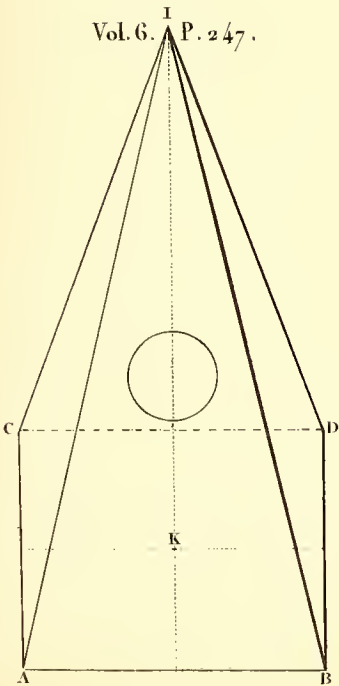

198.

197. bis.

Vol. 6. P. 248.

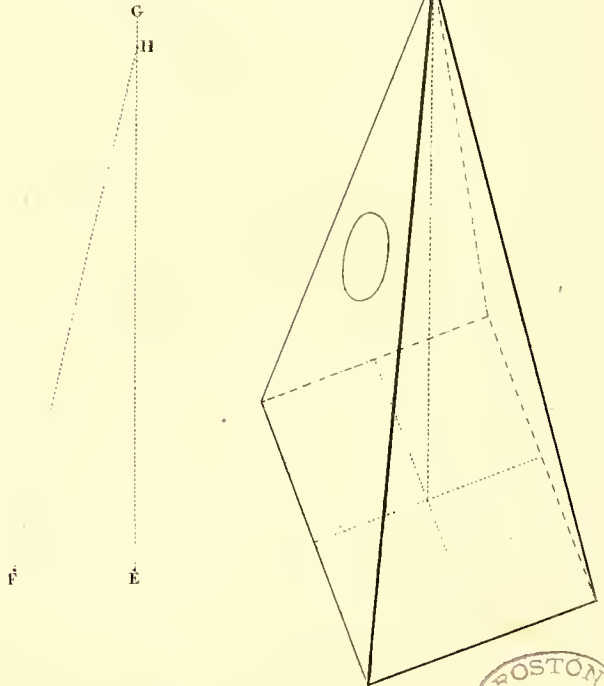

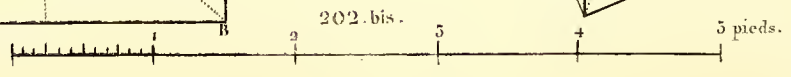
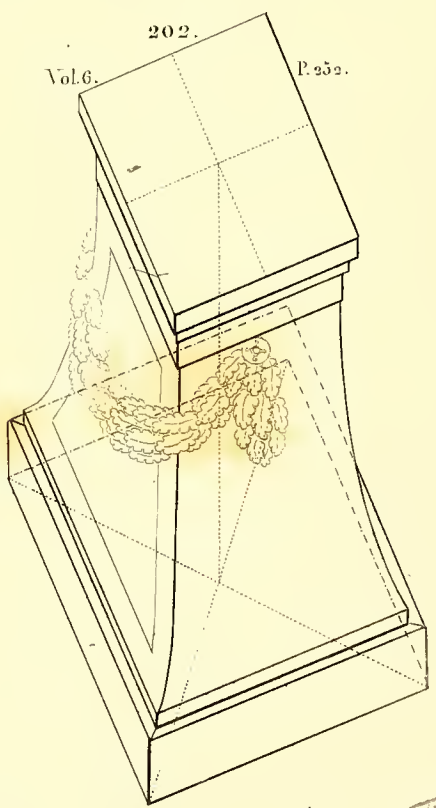
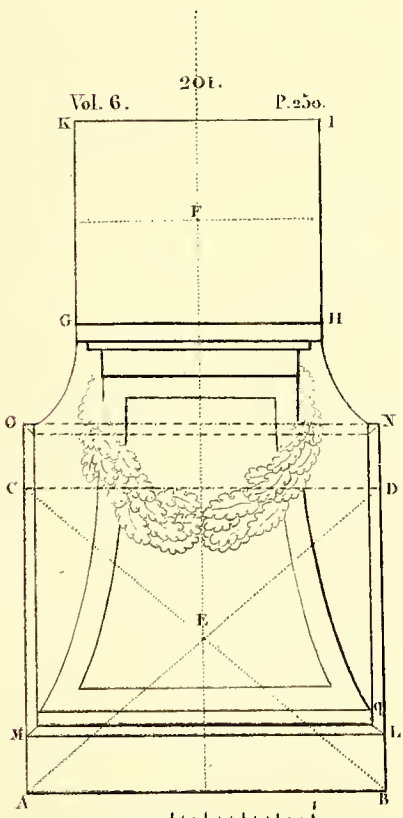
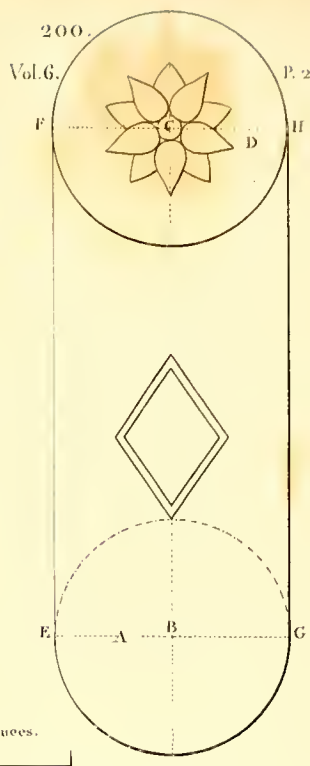
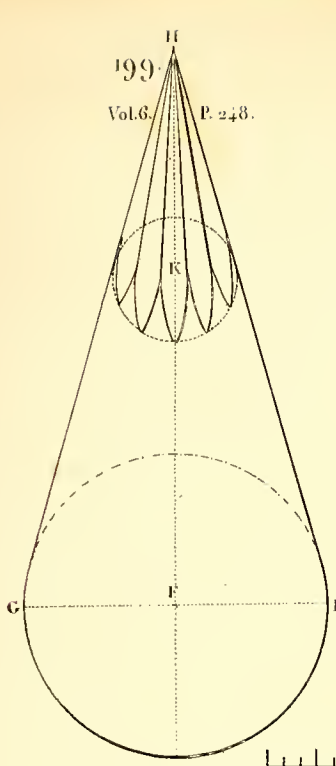

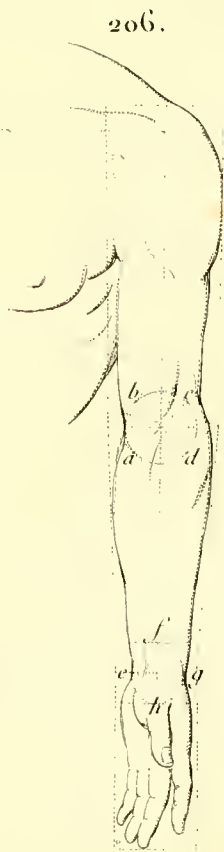
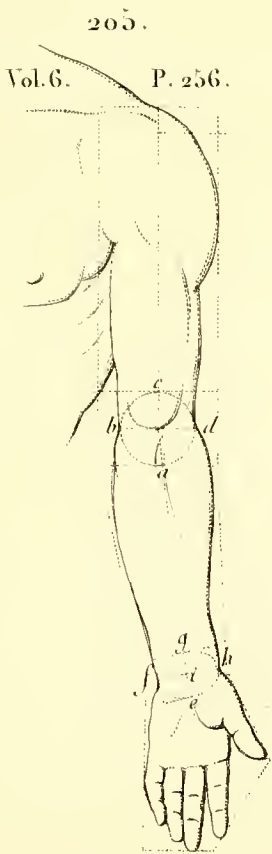
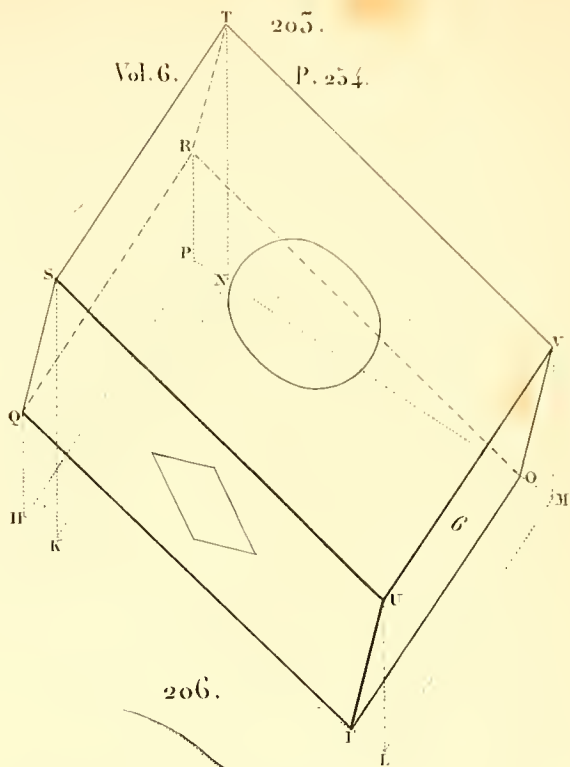
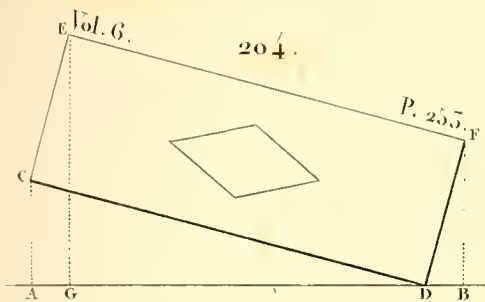

207.

Face du tableau Orthographique.

Tableau Orthographique.

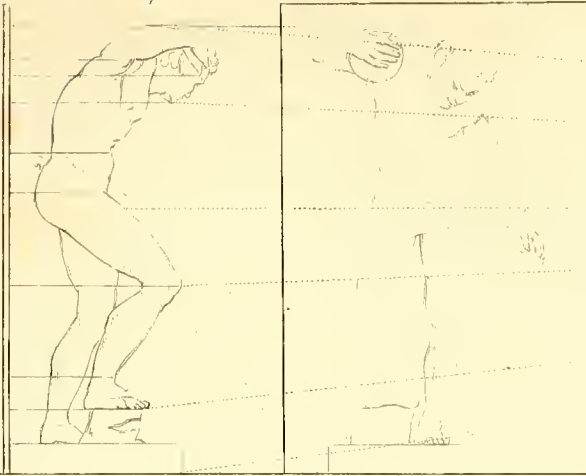

208.

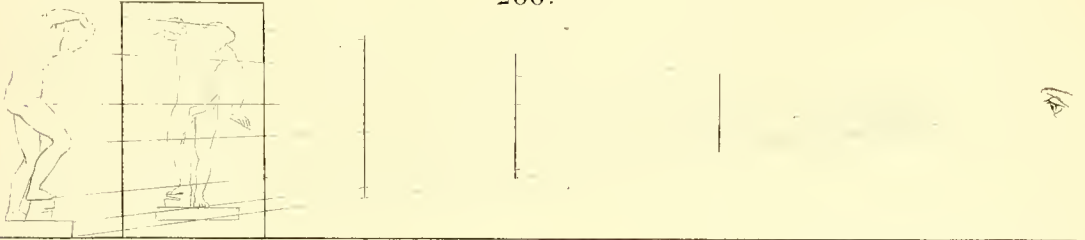

209.

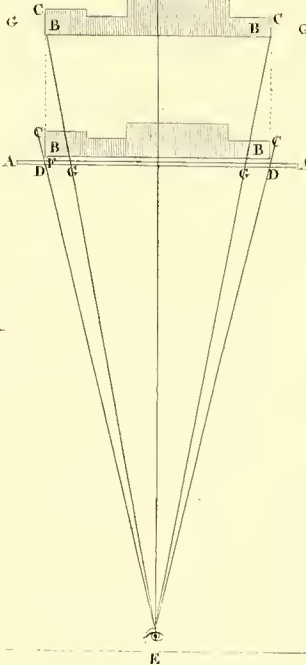

210.

Vol. 6.

P. 267.

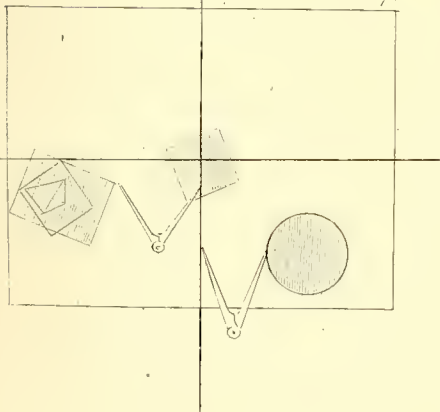

211.

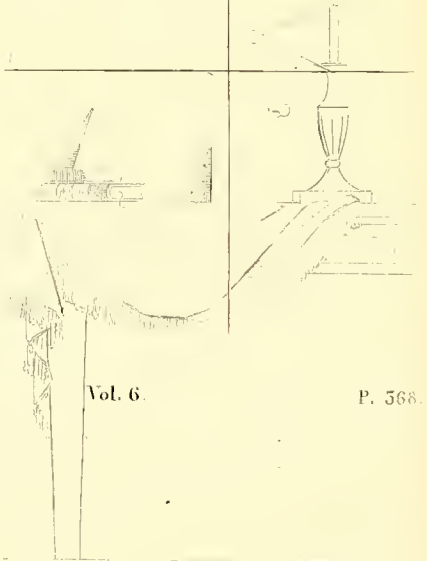

Vol. 6.

P. 368.



F.

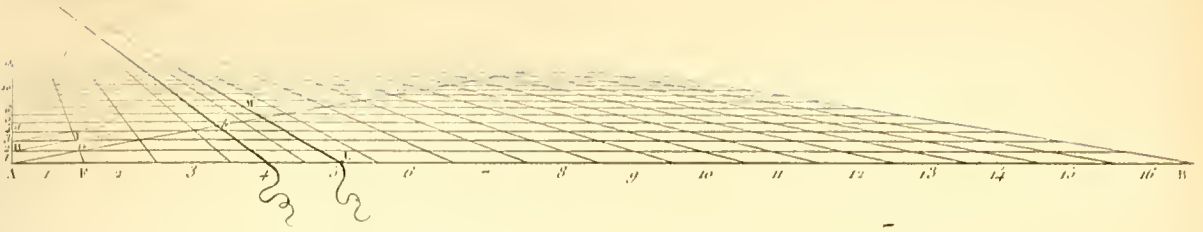

214.

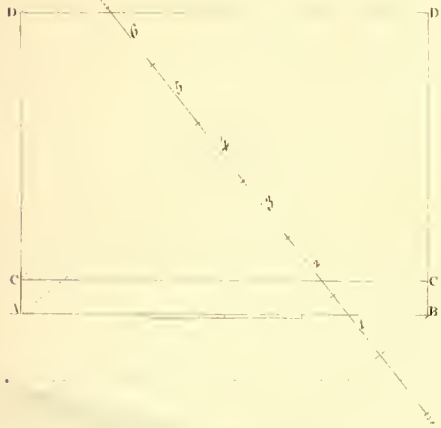

215.

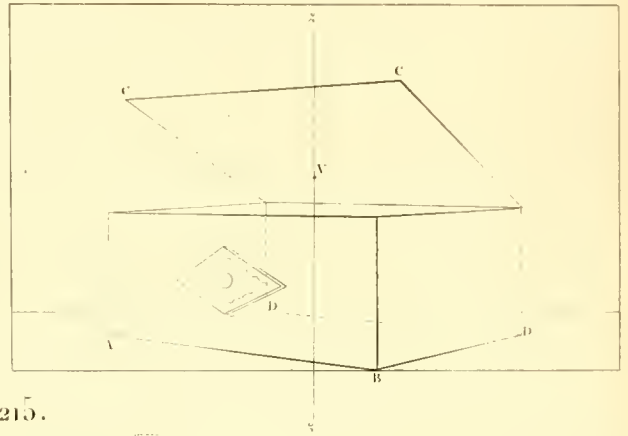

215.

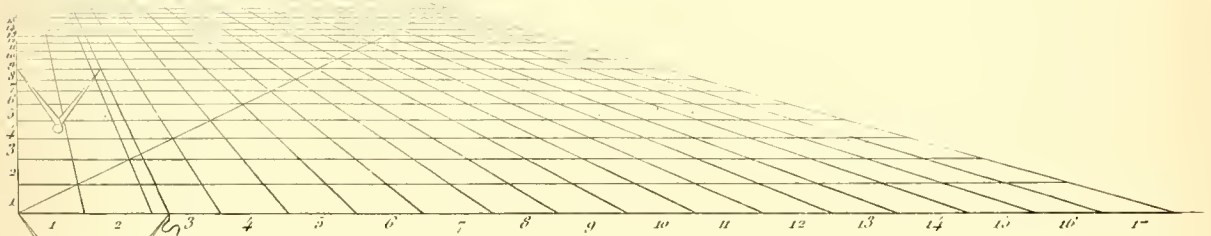

216.

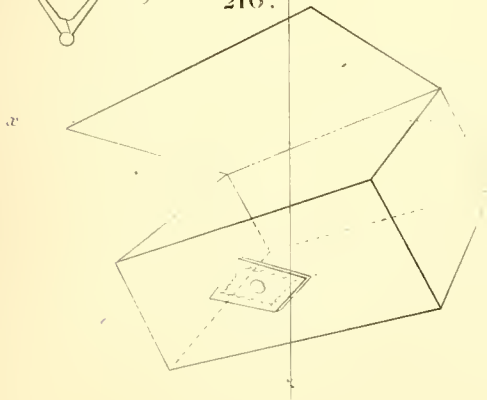

252. bis.

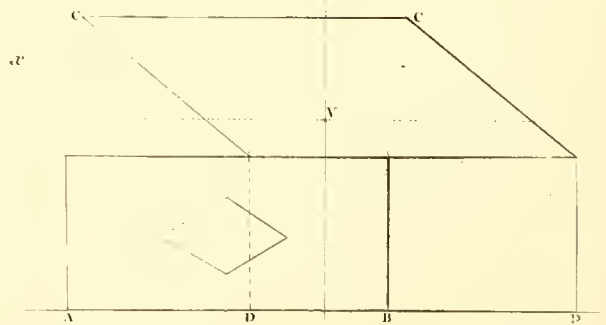

217.

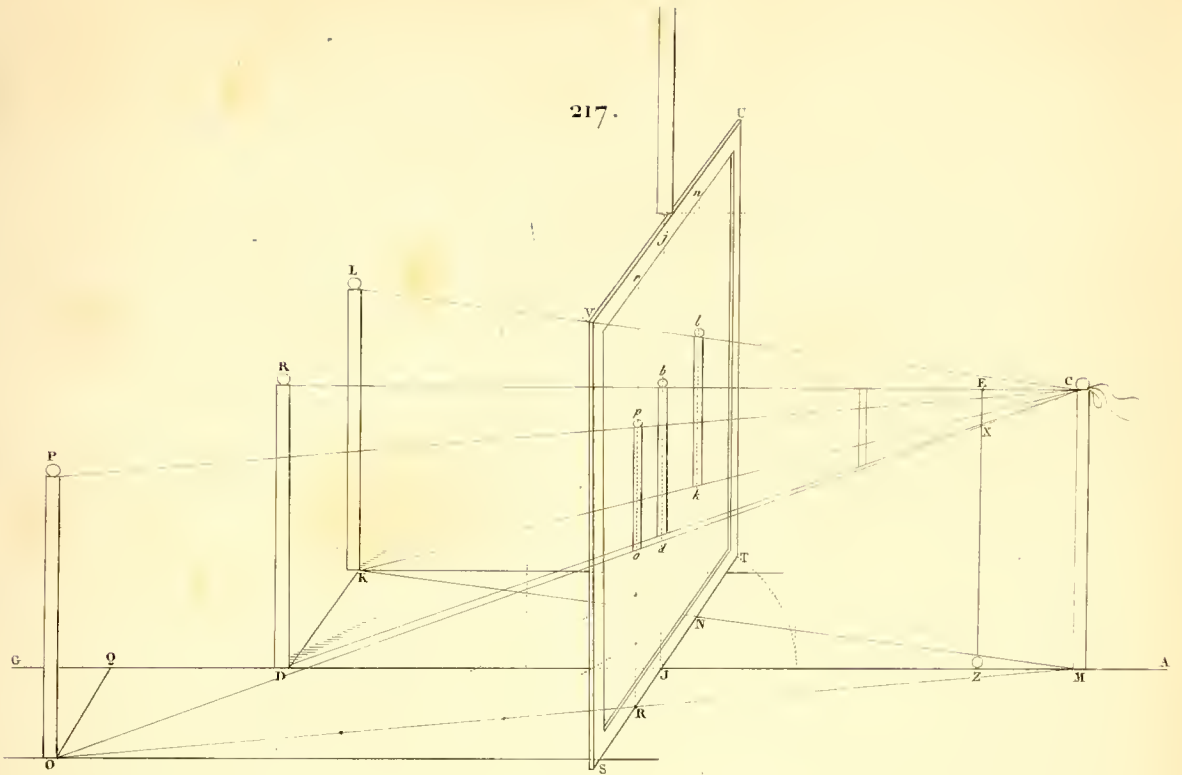

218.

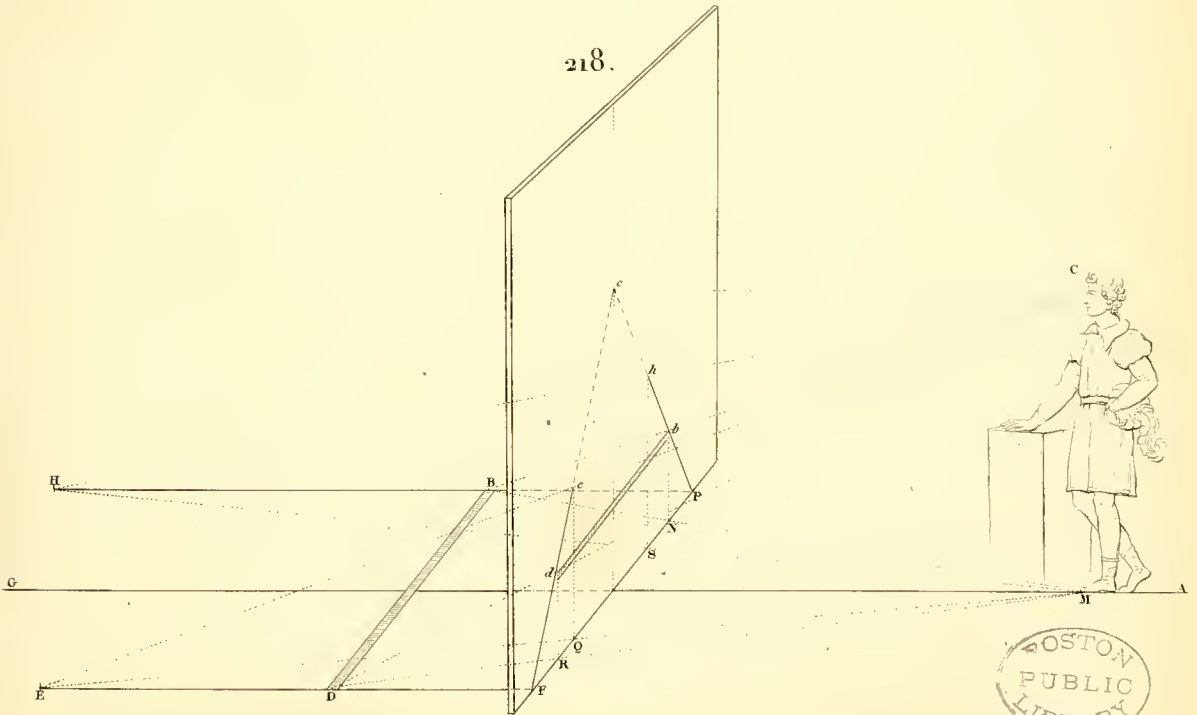

219.

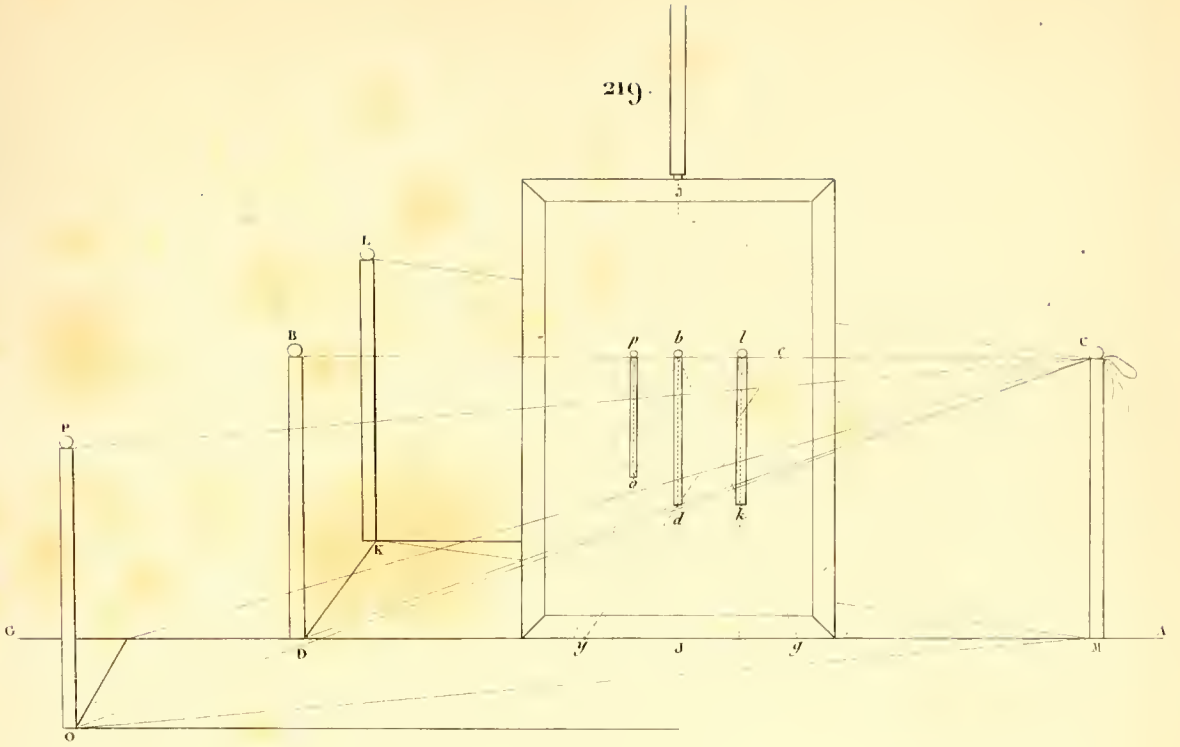

222.

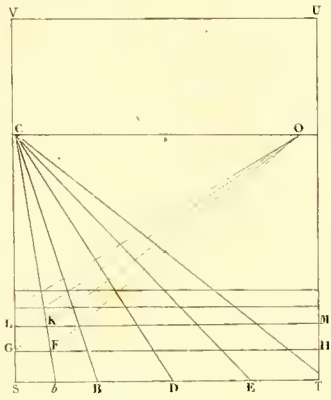

221.

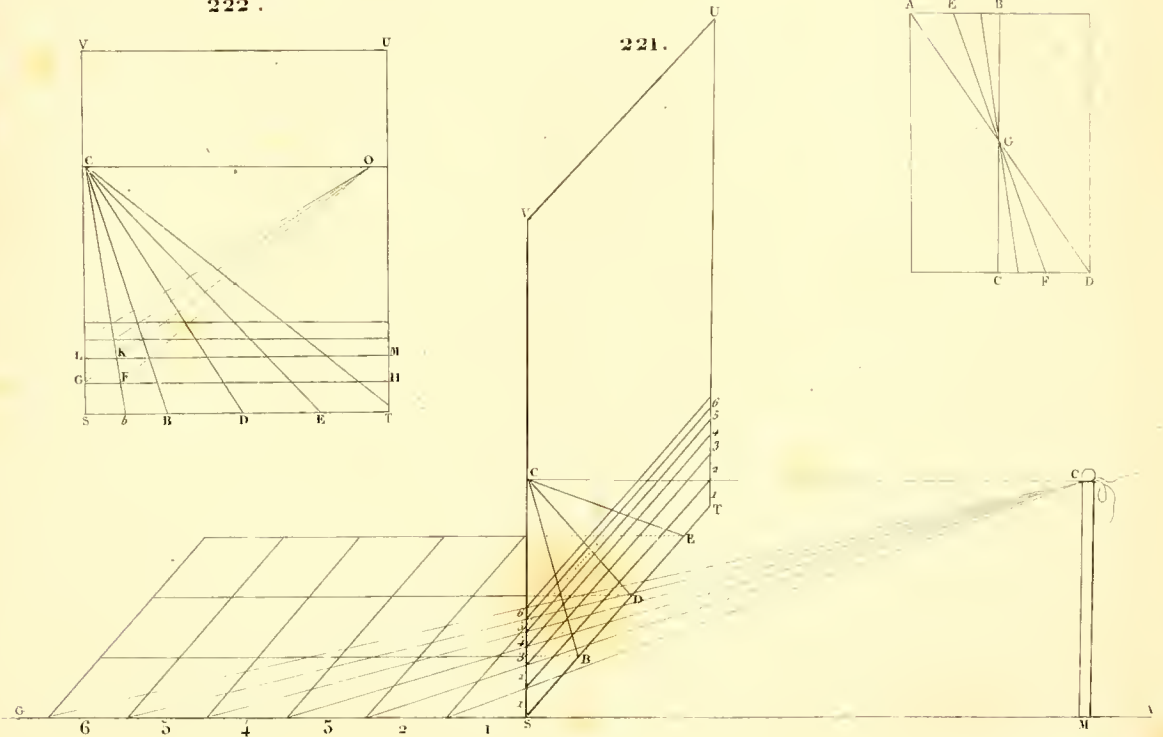

220.

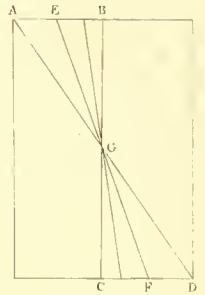

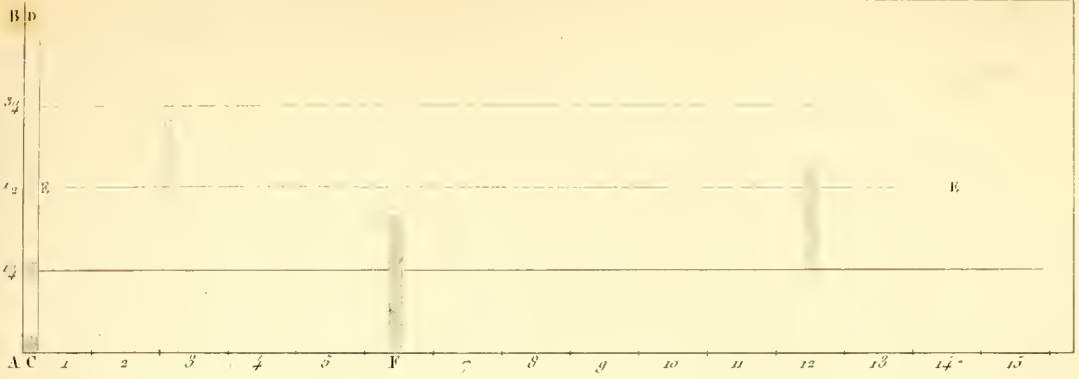

Application de l'échelle linéaire abrégée.

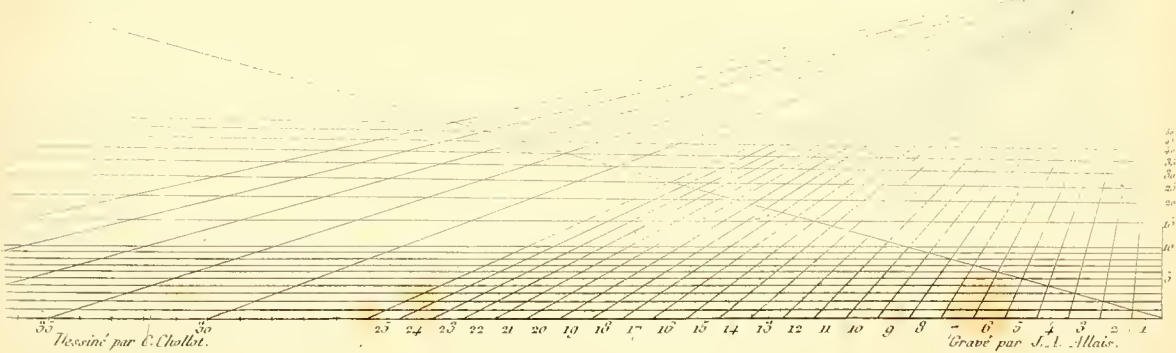

Dessiné par C. Chollot.

Gravé par J. L. Mais.



225.

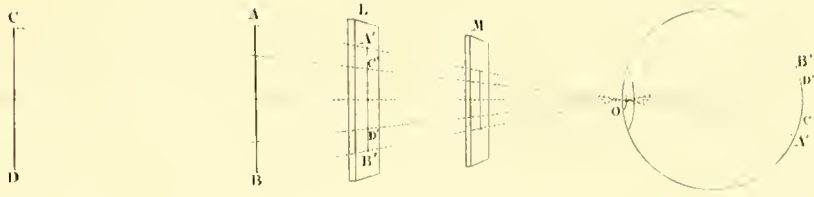

226.



227.

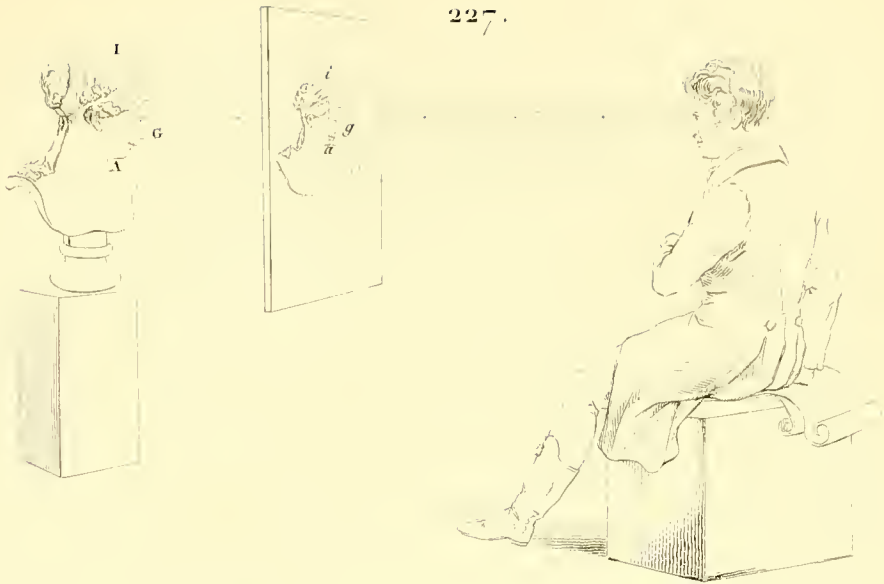

228.

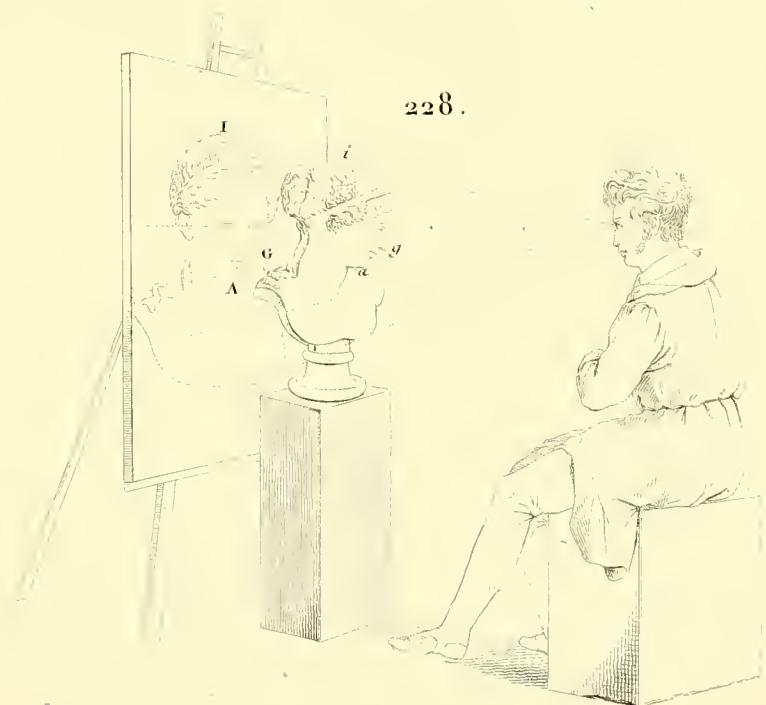

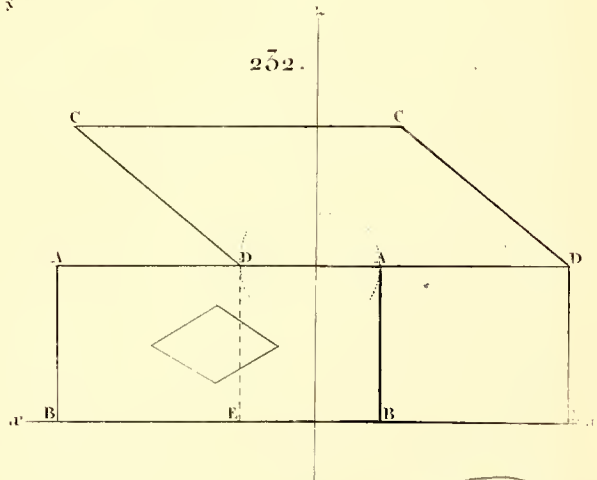
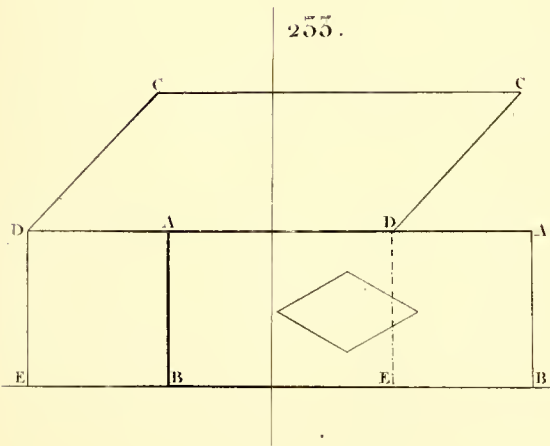
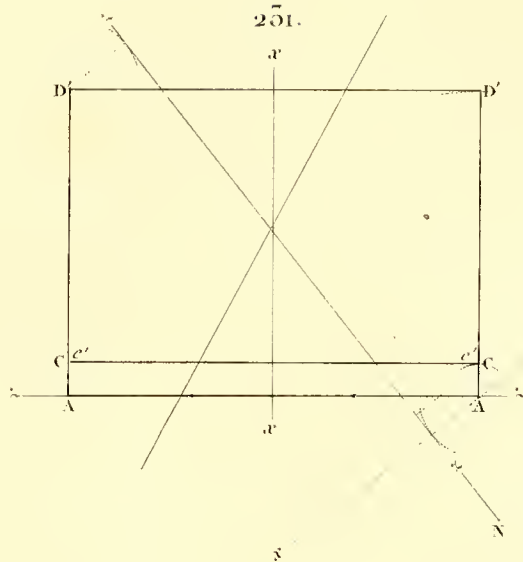
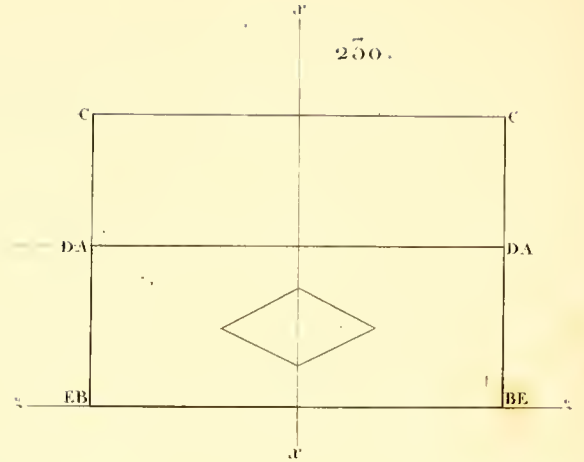
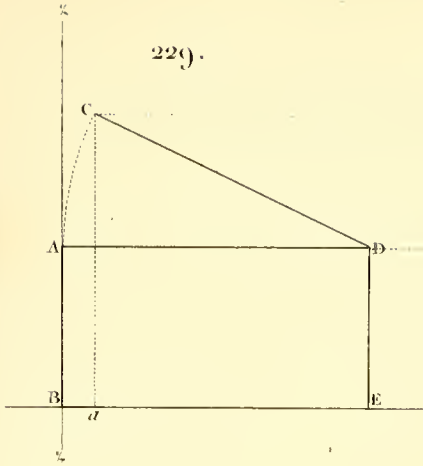



254.

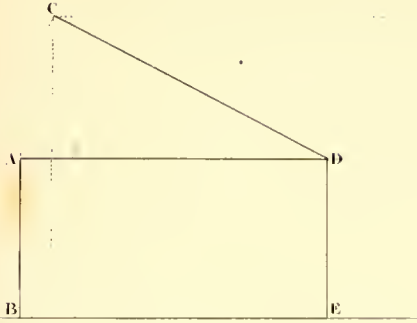

255.

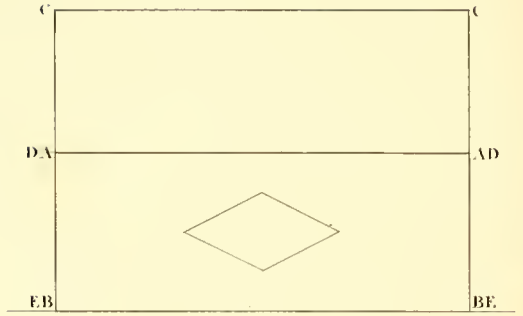

259.

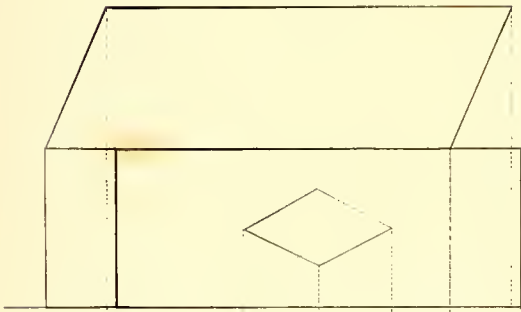

258.

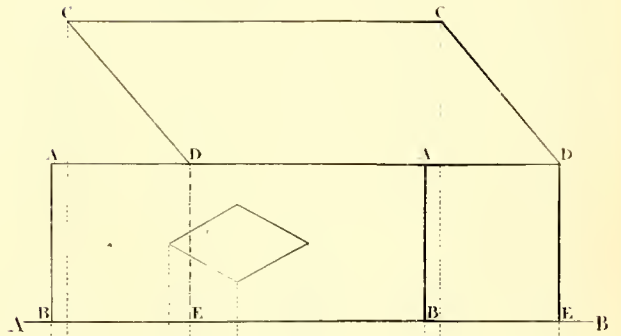

257.

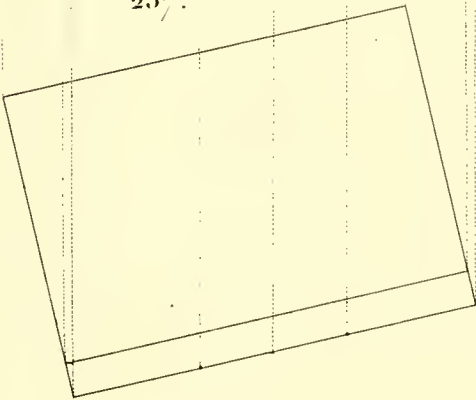

256.

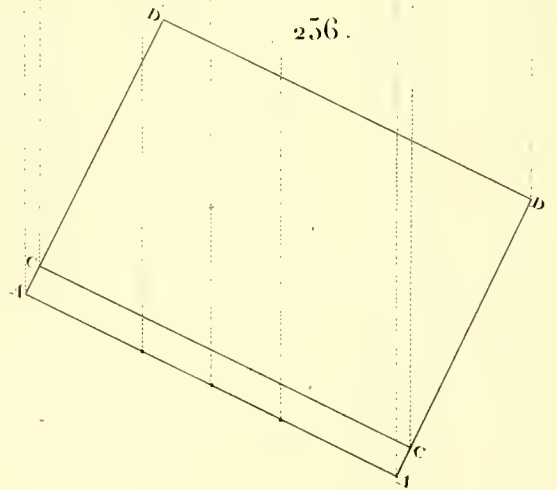

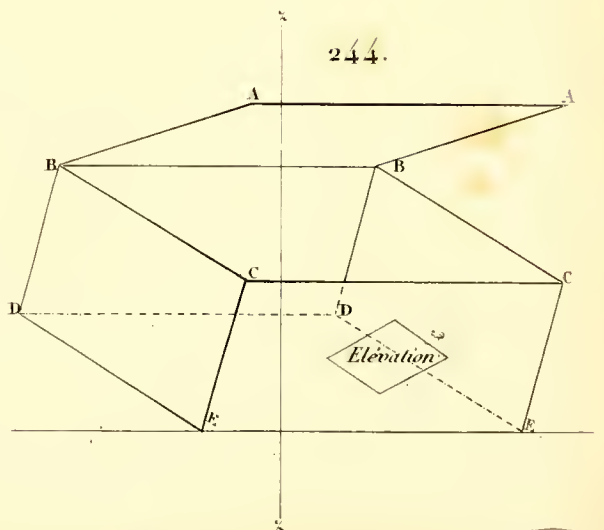
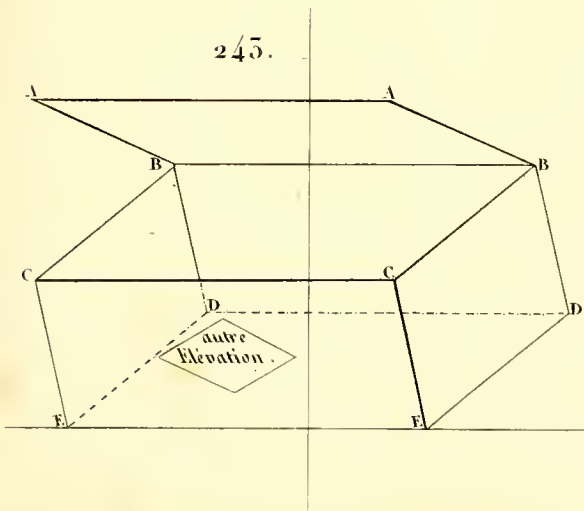
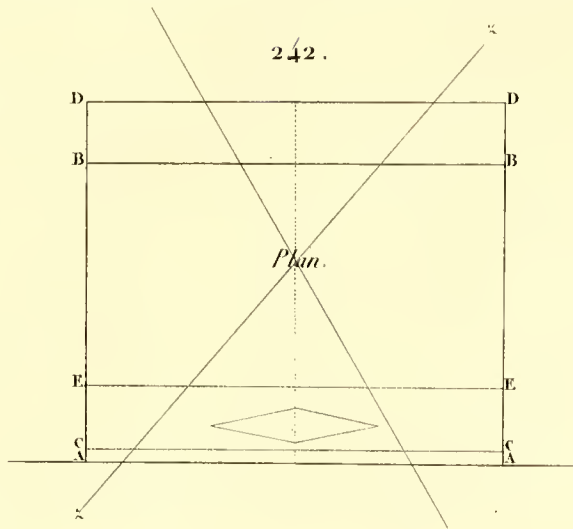
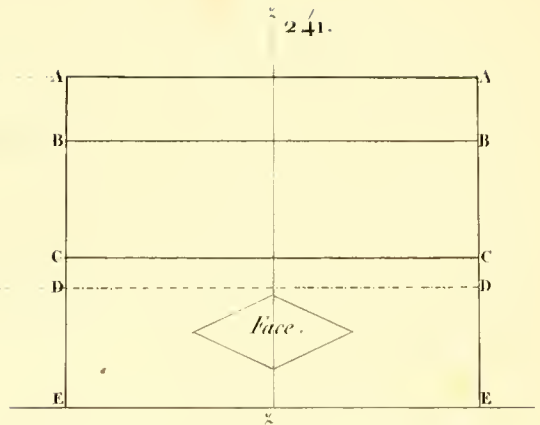
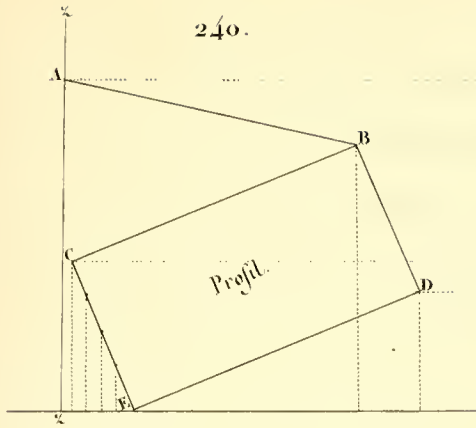



245.

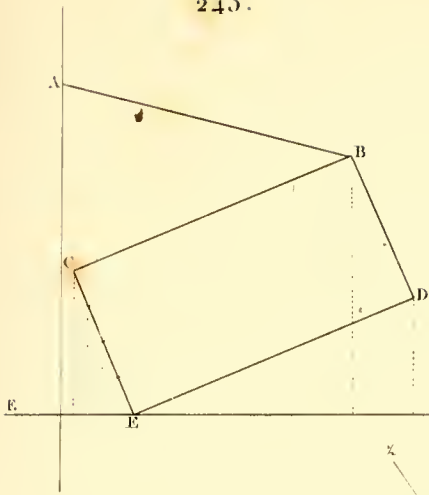

246.

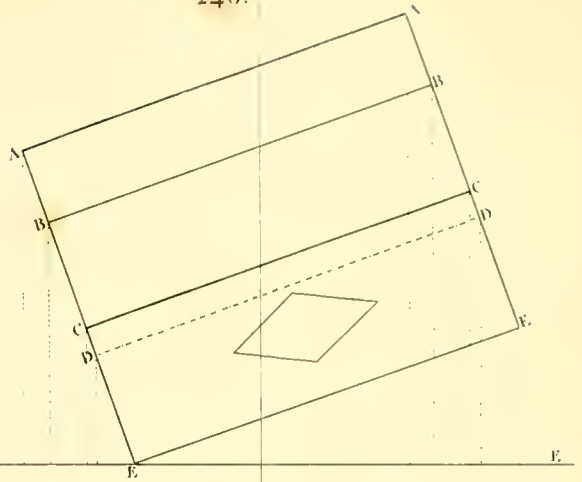

247.

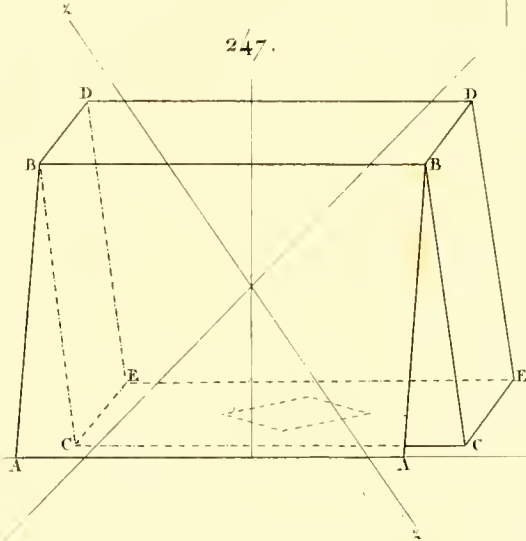

249.

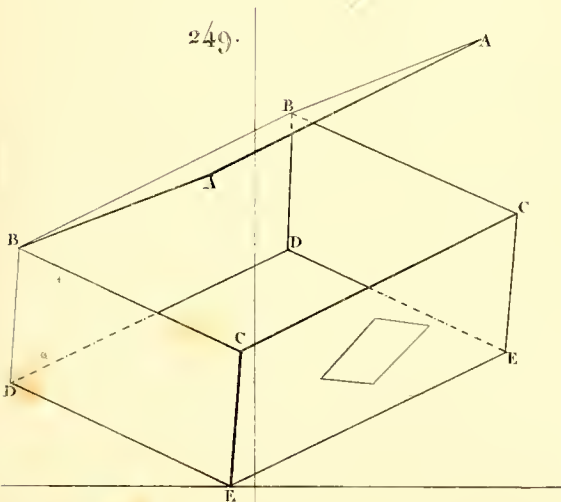

248.

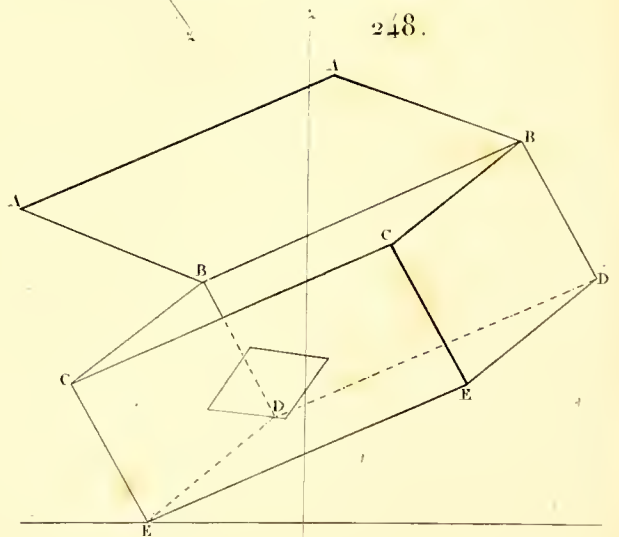

Dessiné par C. Chollot.

Gravé par J. Allaire.



250.

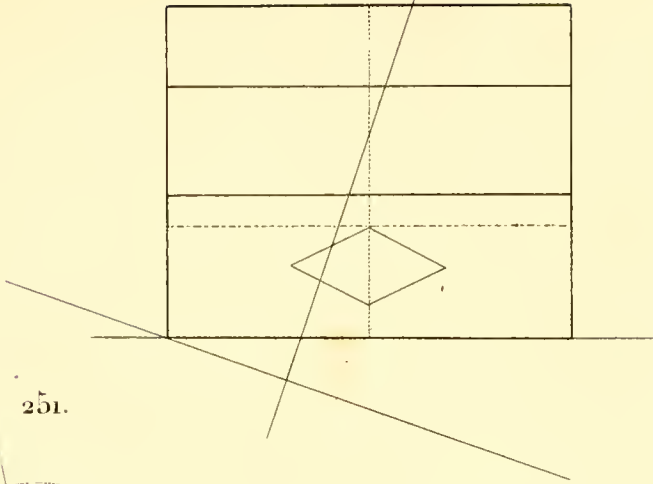

251.

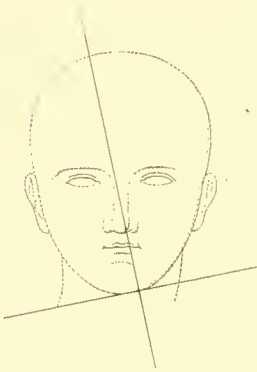

252.

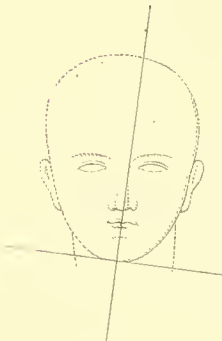

253.

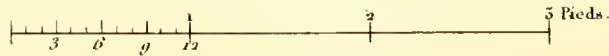
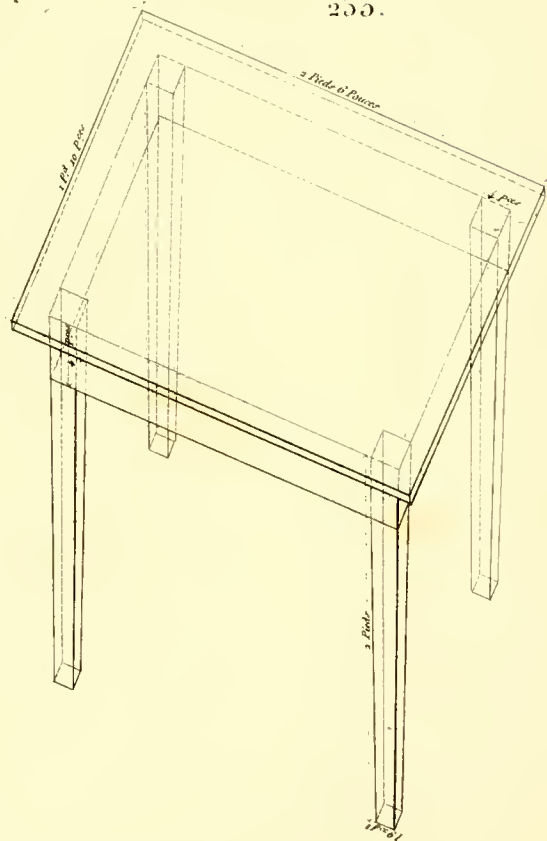

254.

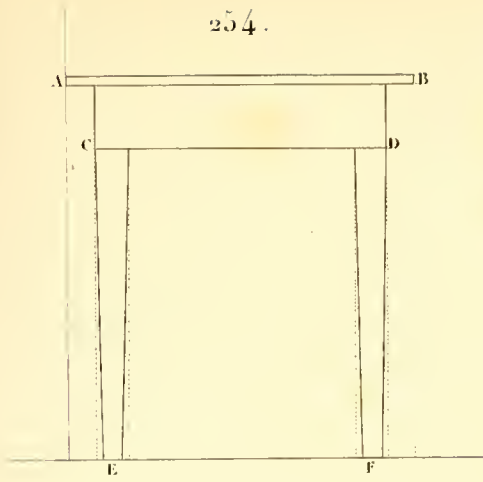

255.

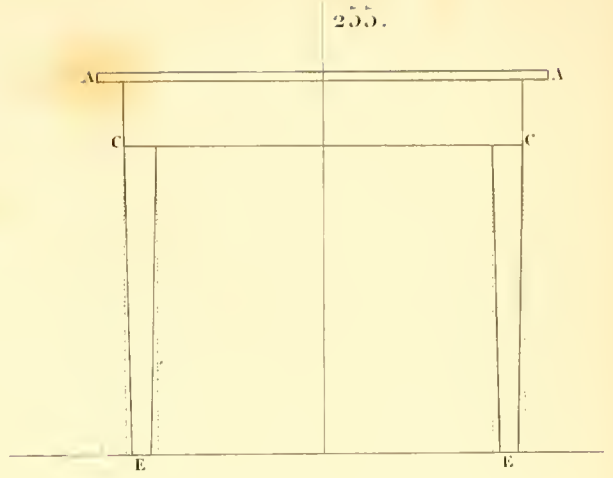

256.

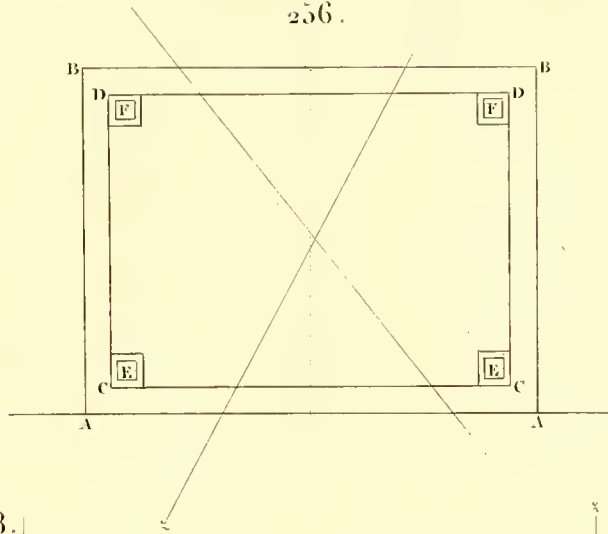

258.

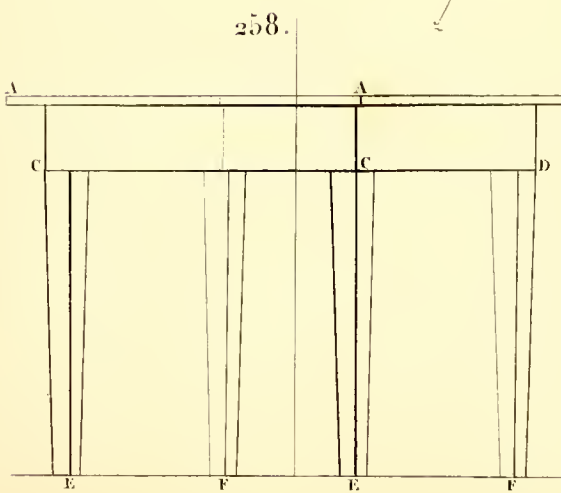

257.

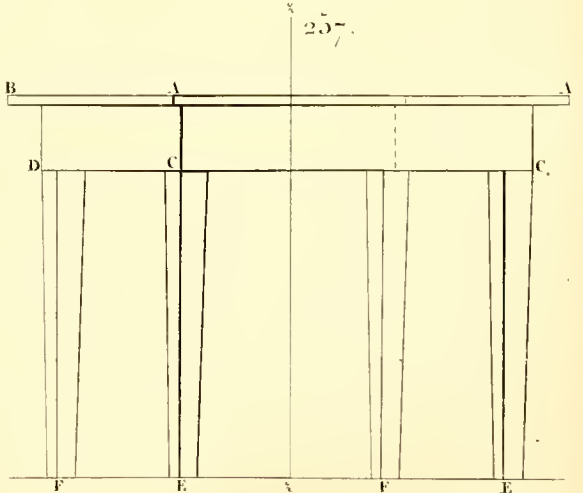

259.

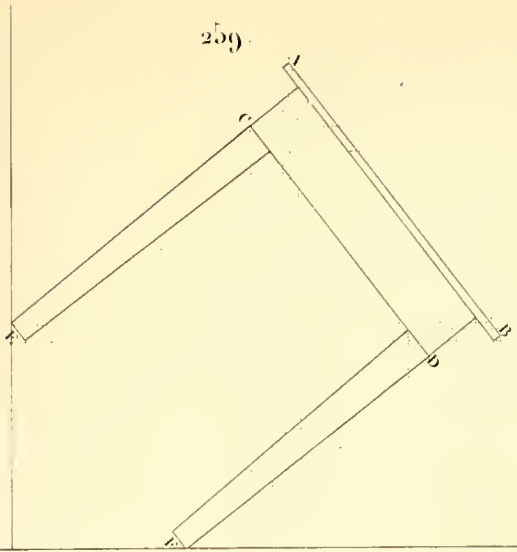

260.

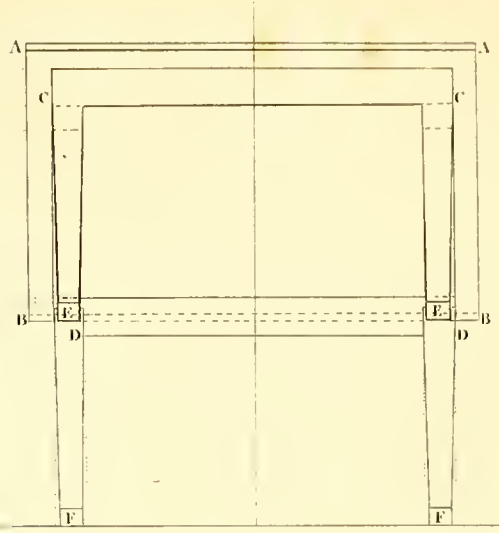

261.

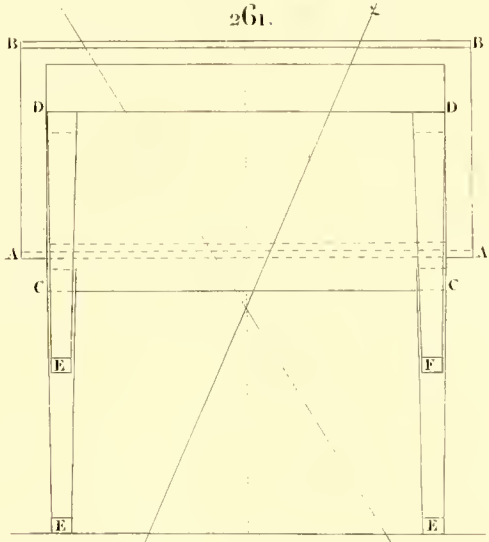

265.

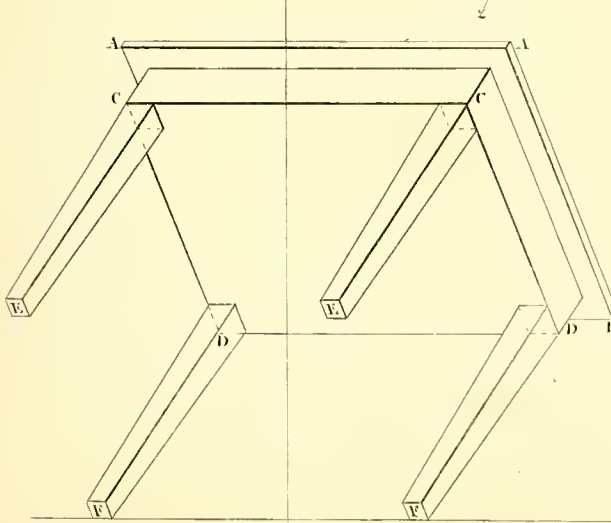

262.

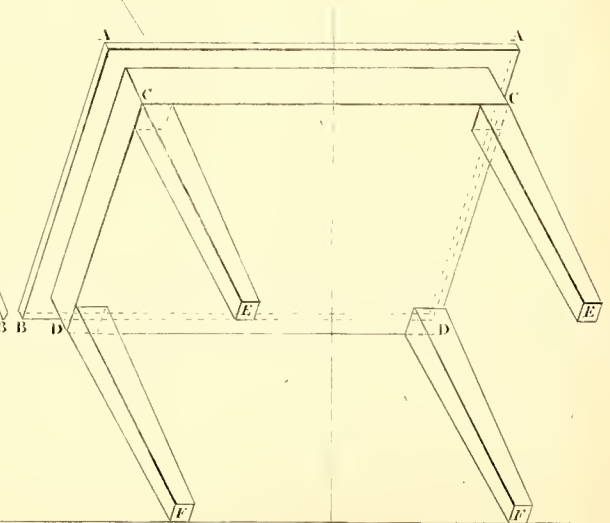

Dessiné par C. Chollot.

Gravé par J. A. Alla.



264.

265.

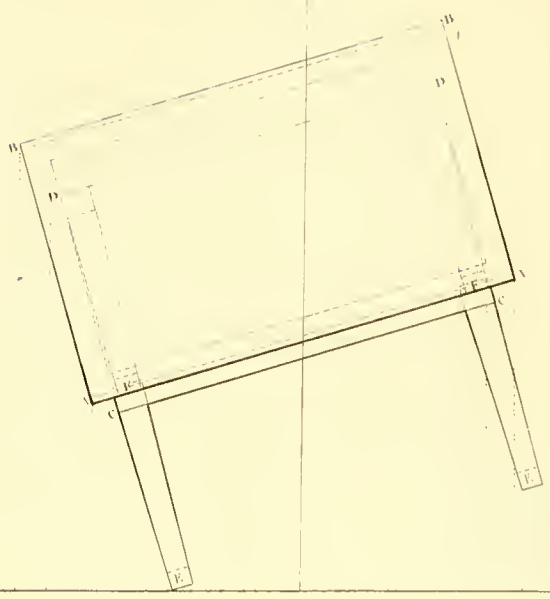
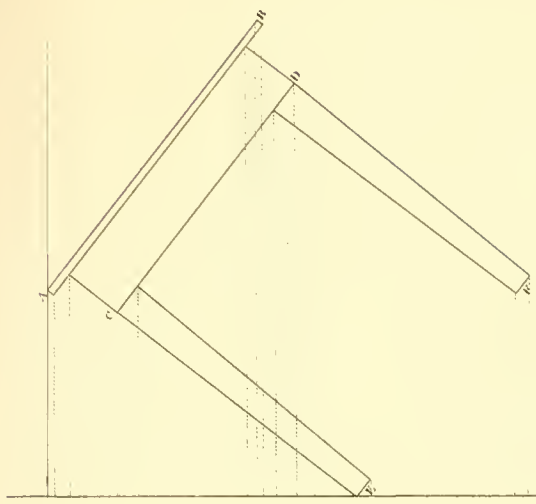

267.

266.

Plan.

Elevation.

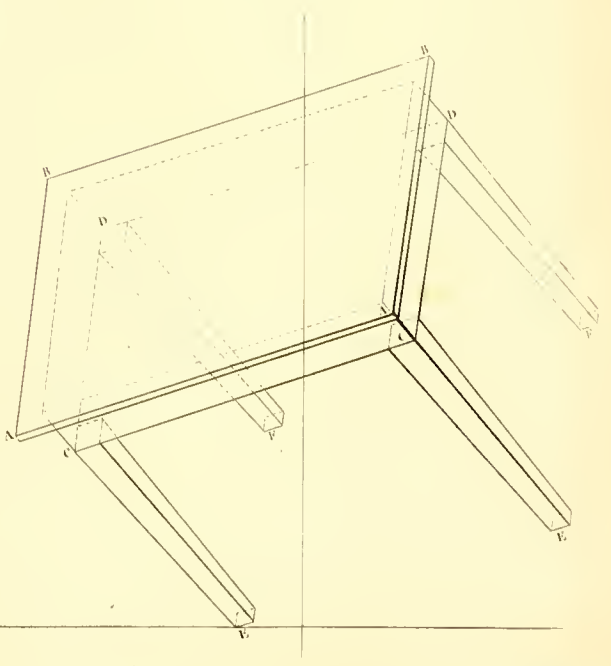
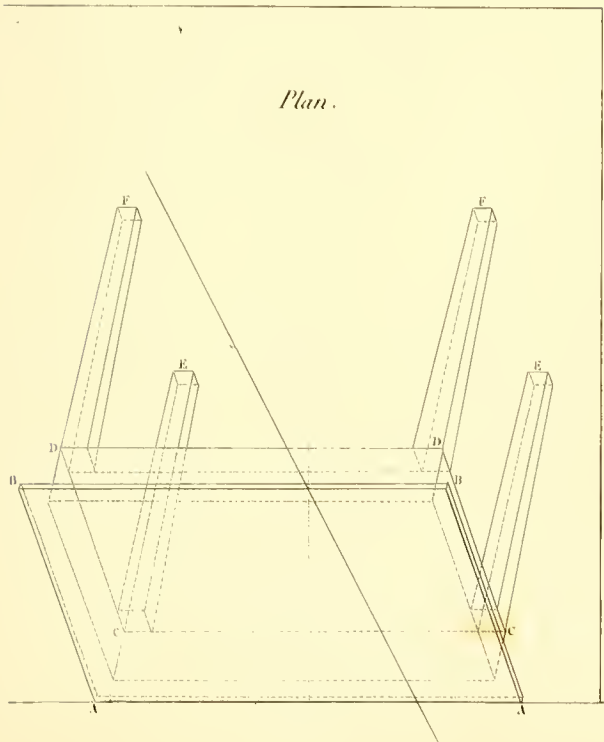

268.

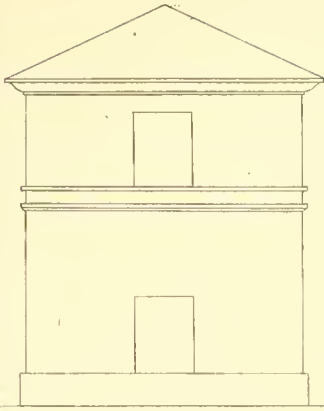

269.

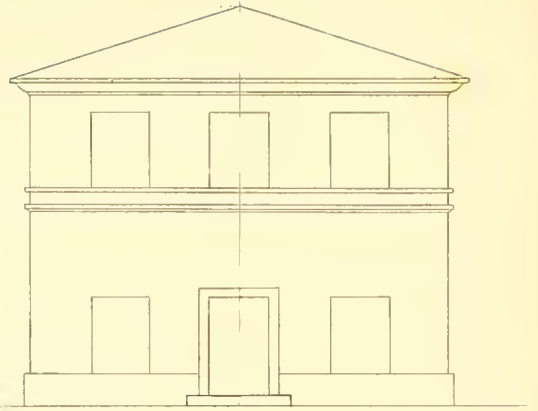

270.

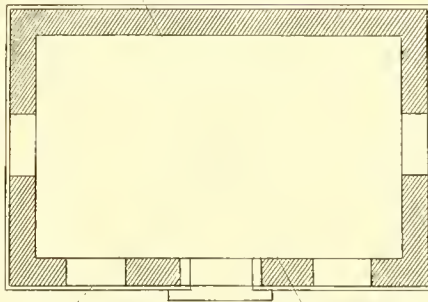

272.



271.

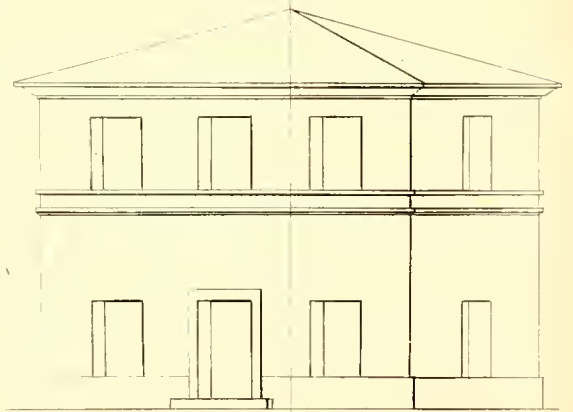

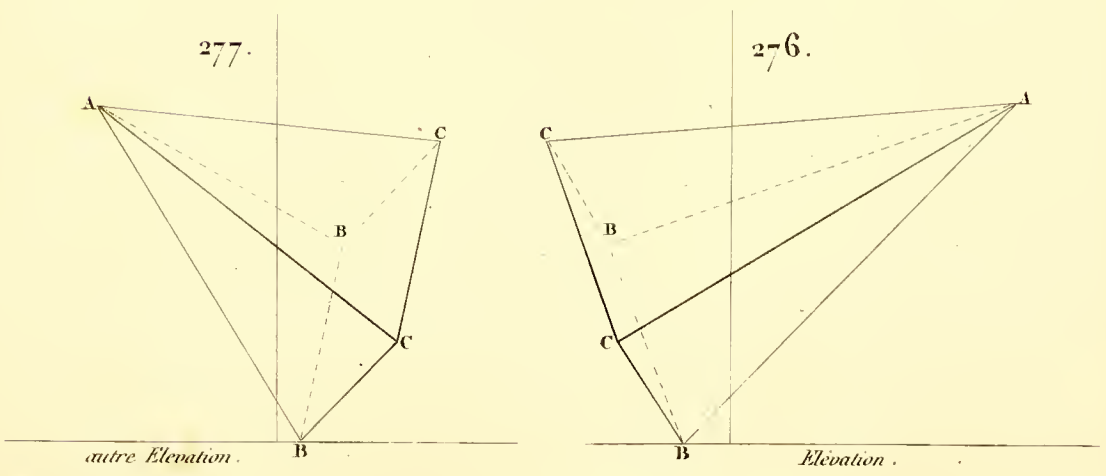
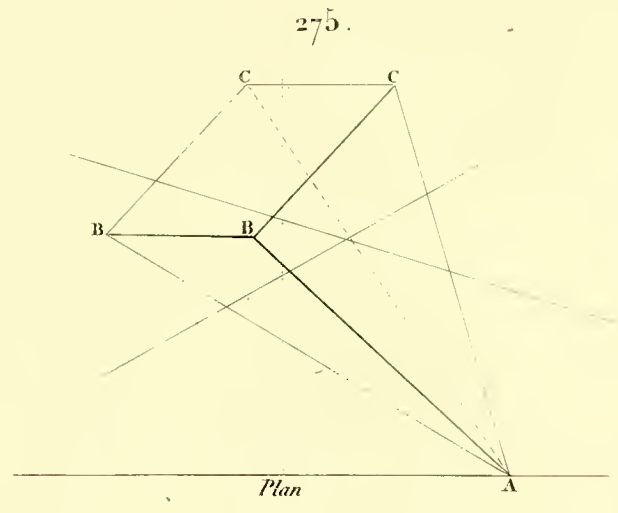
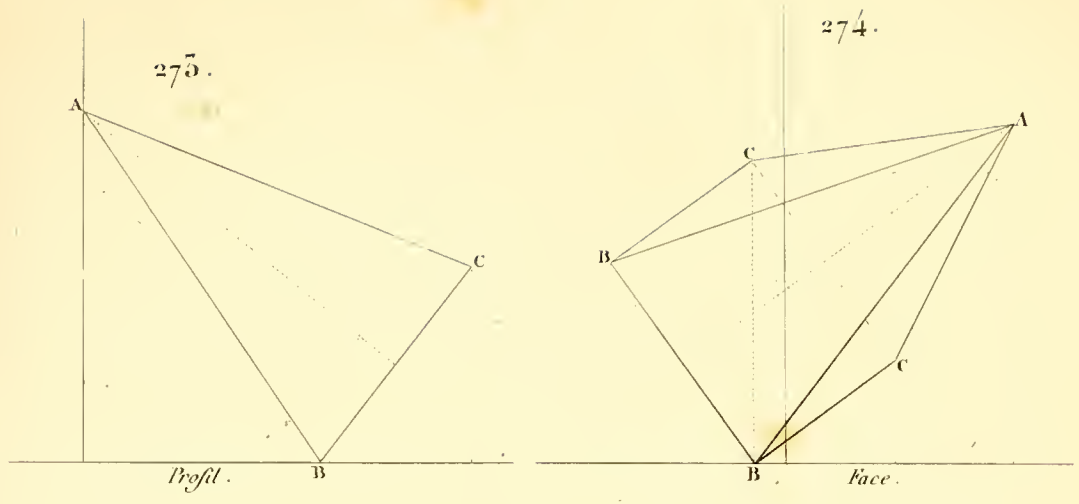

Dessiné par C. Chollot.

Gravé par J. A. Allais



278.

279.

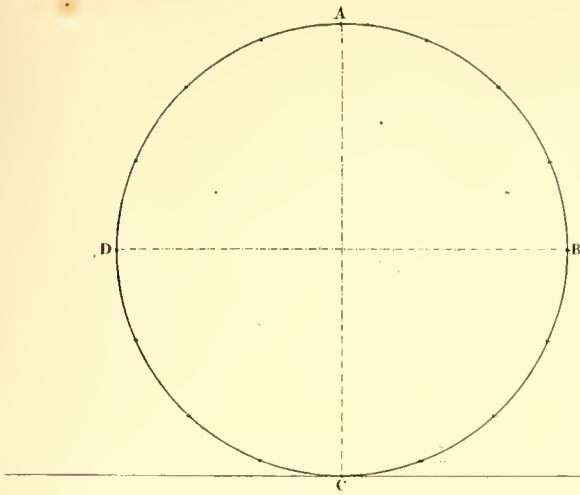

Plan

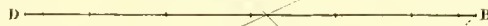

Autre aspect

281.

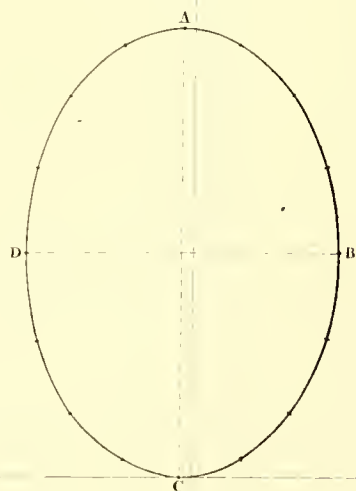
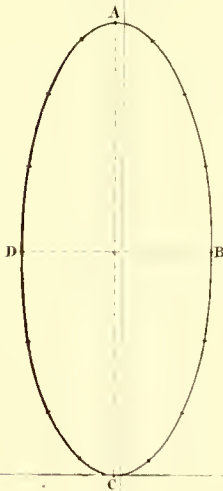

Le Cercle précédent renversé en arrière.

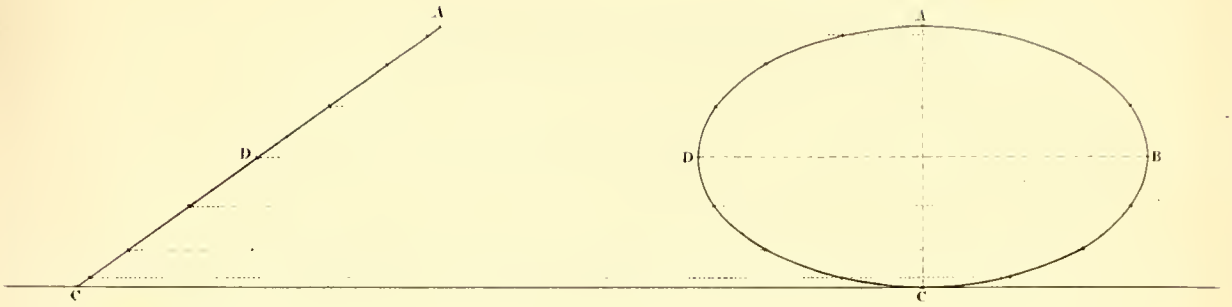

Plan.

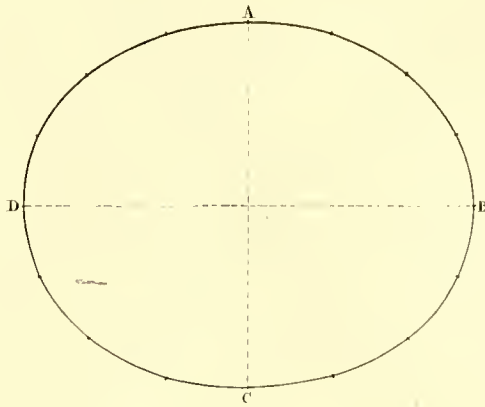

Elevations.

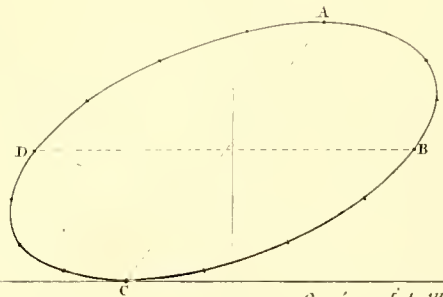
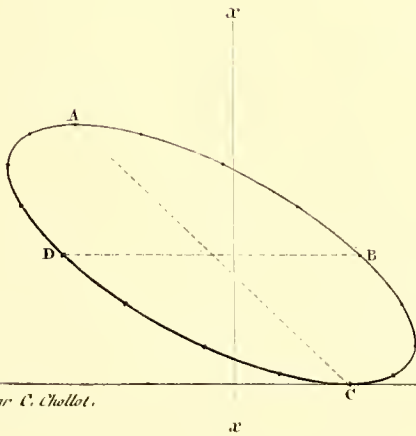

Dessiné par C. Chollot.

Gravé par J.-L. Allais.



283.

284.

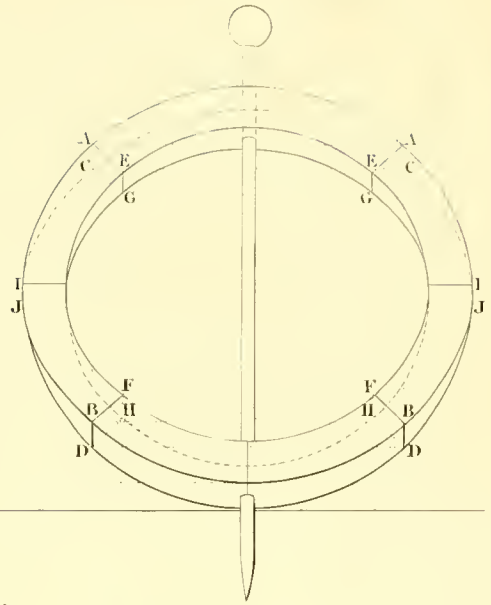
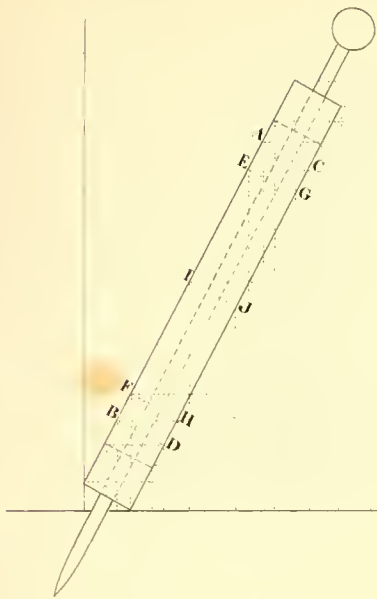

285.

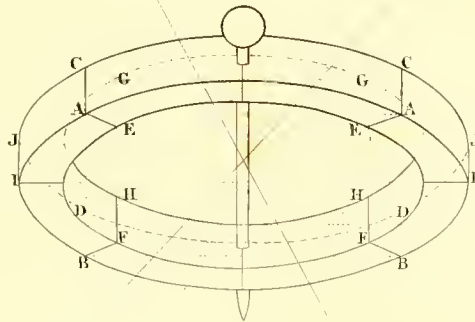

286.

287.

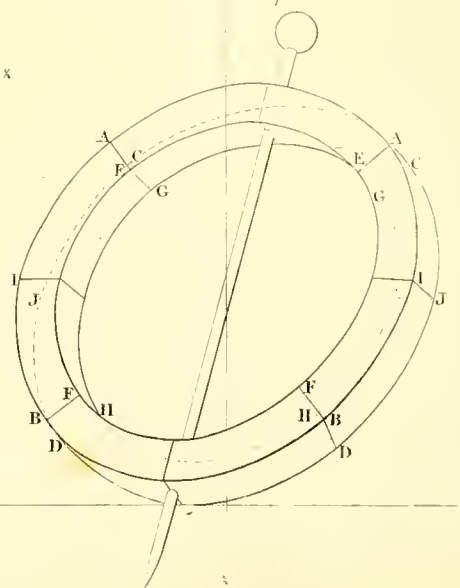
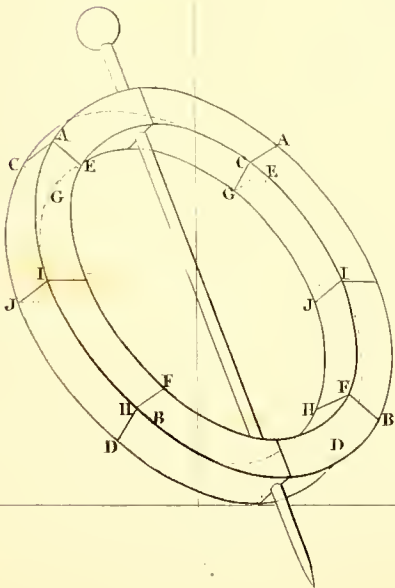

289.

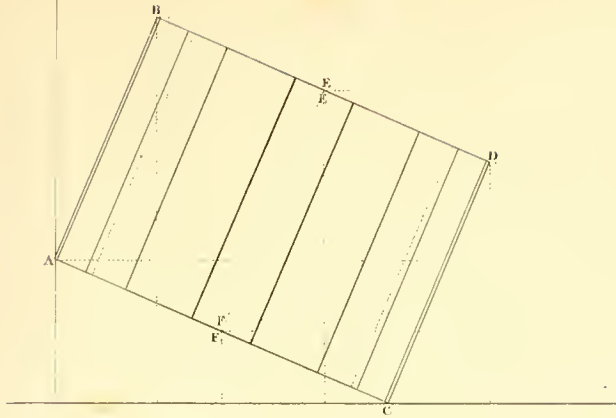

290.

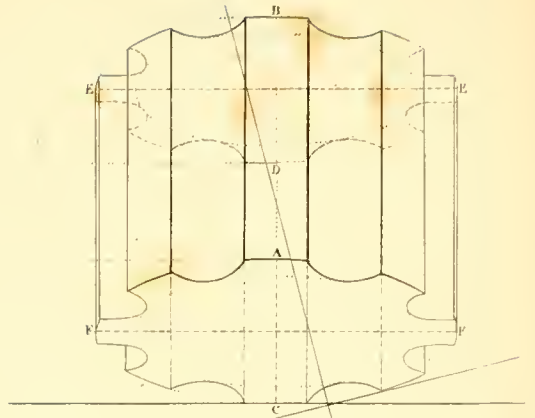

288.

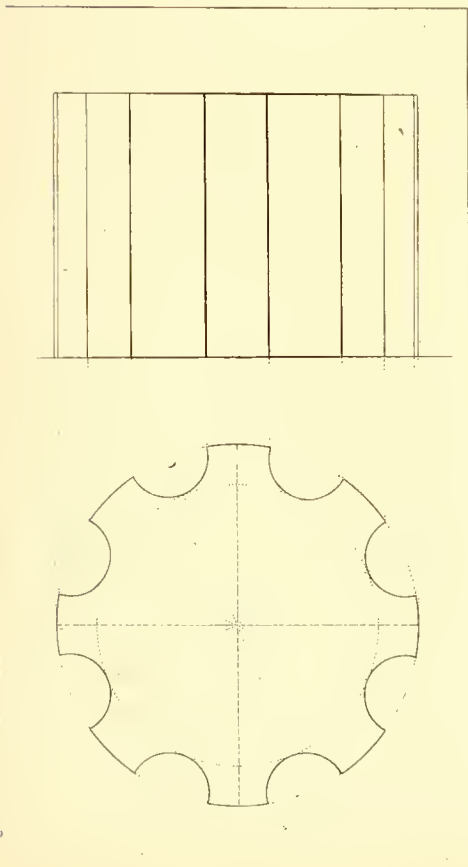

291.

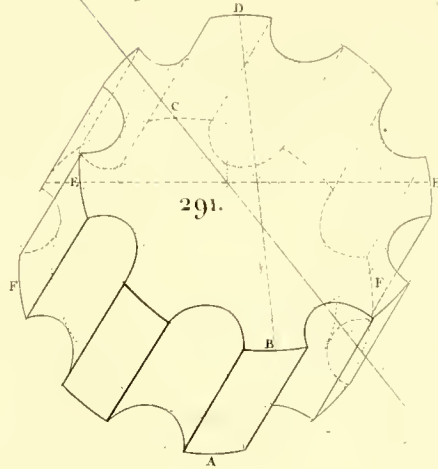

292.

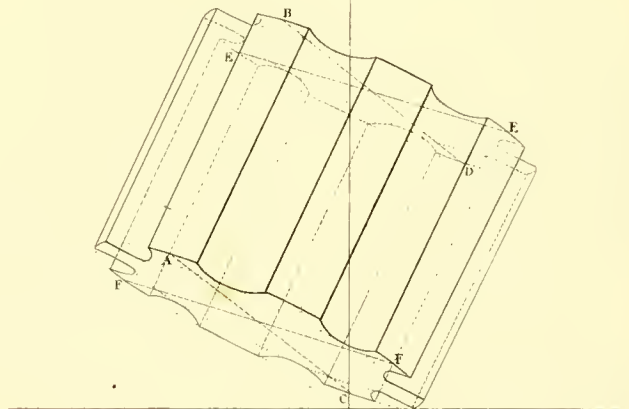

294.

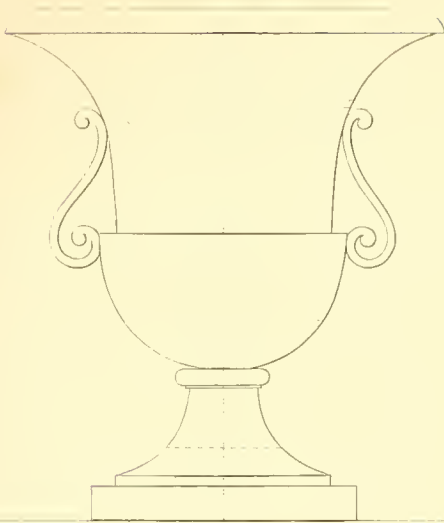

295.

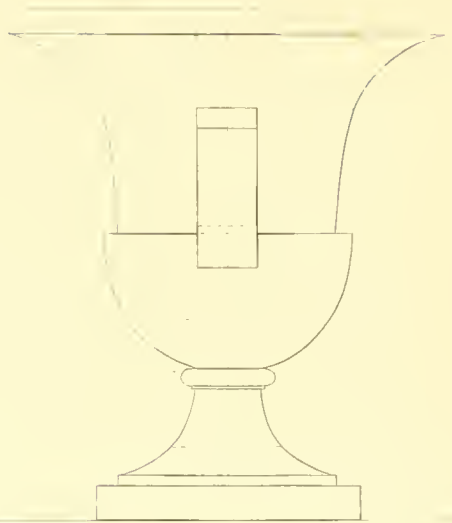

295.

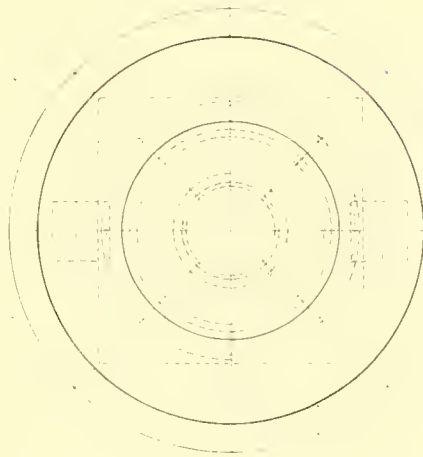

296.

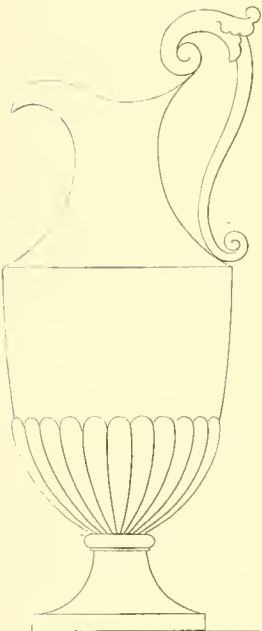

Face.

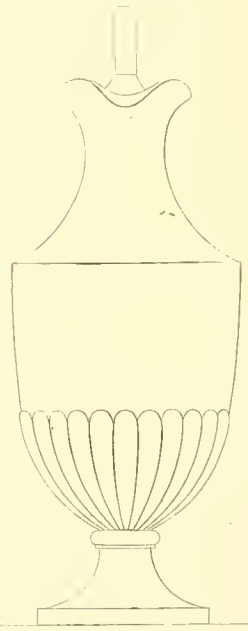

297.

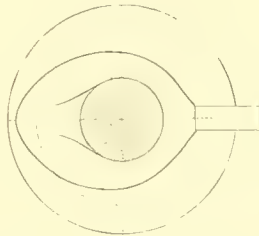

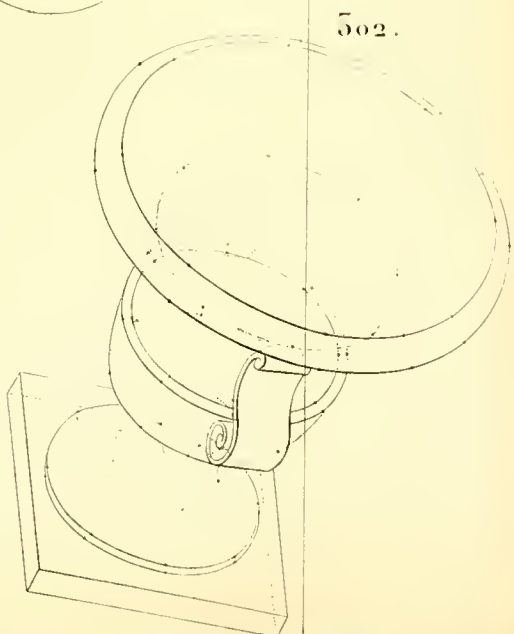
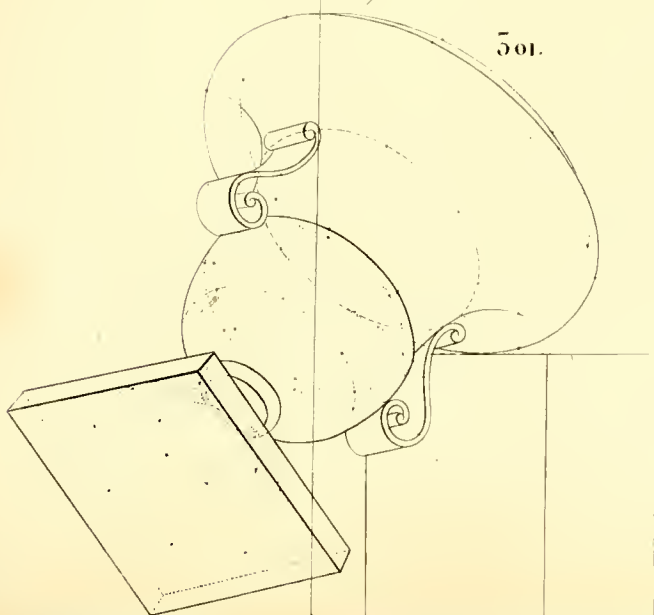
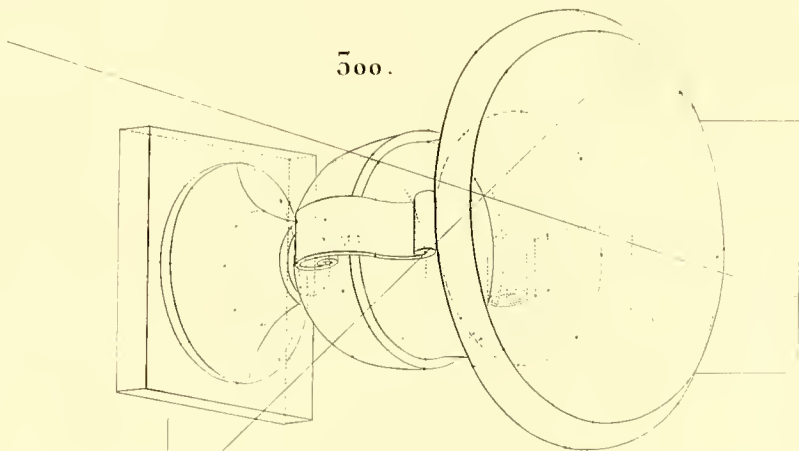
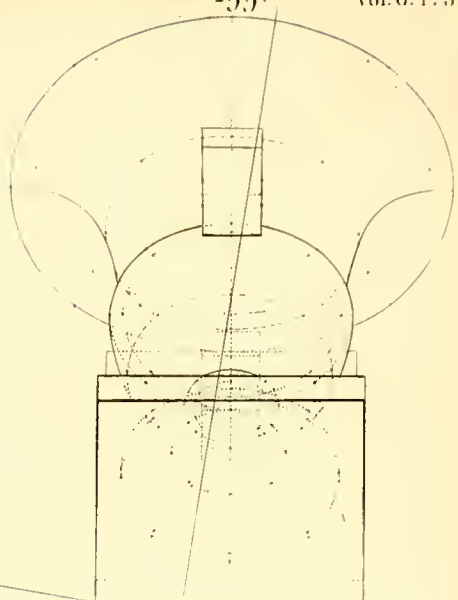
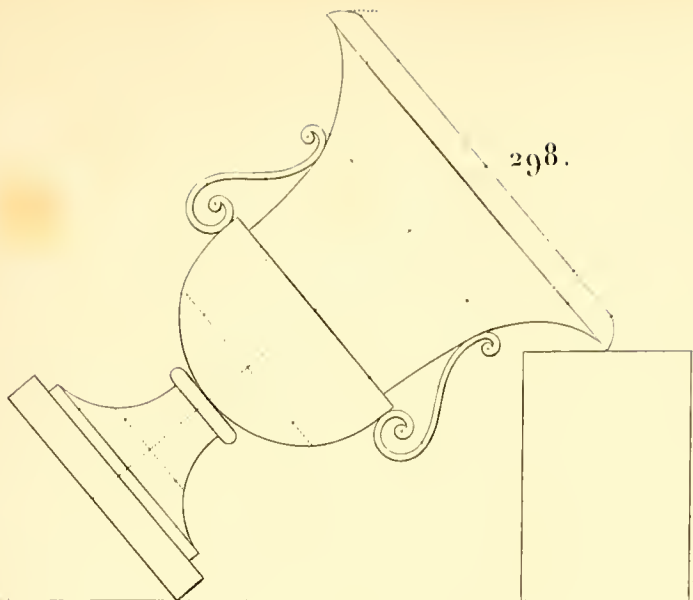



505.

504.

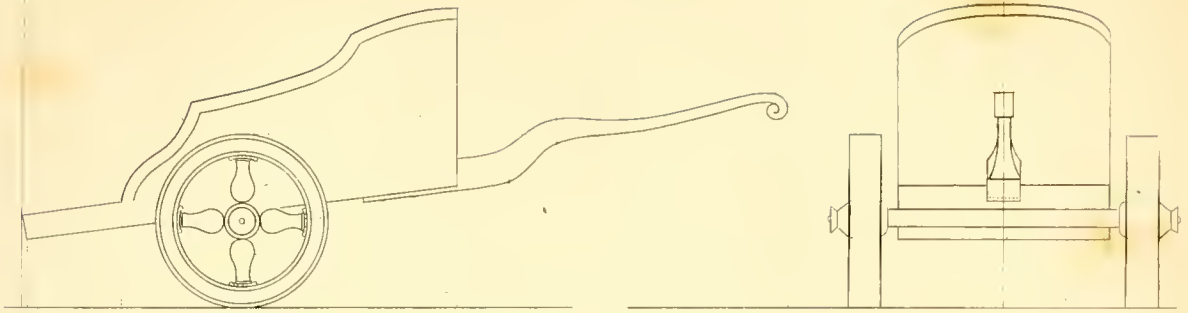

505.

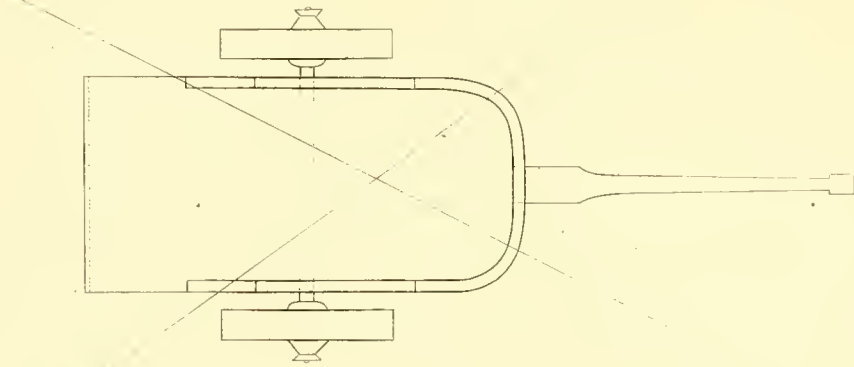

507.

506.

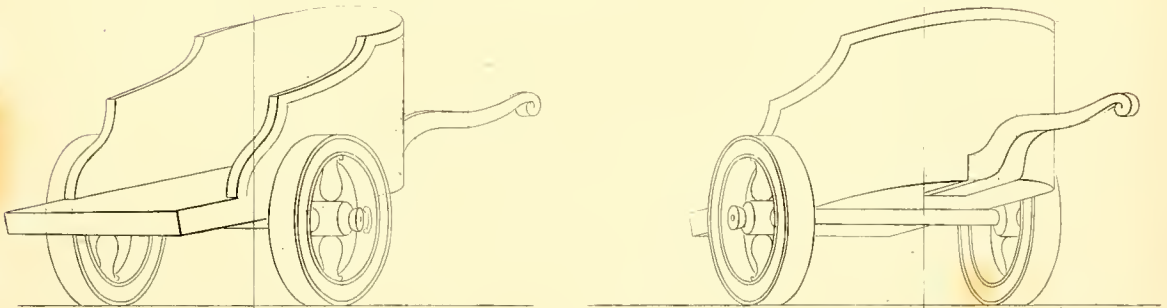

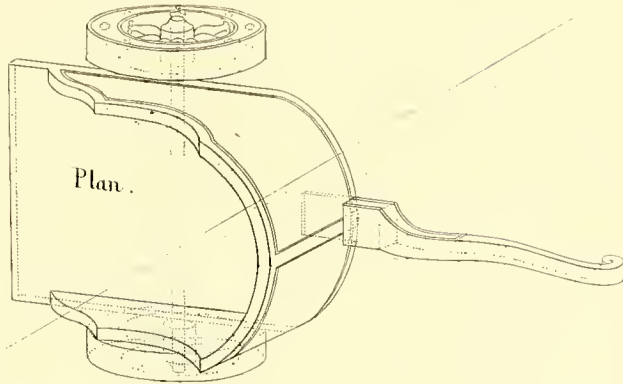
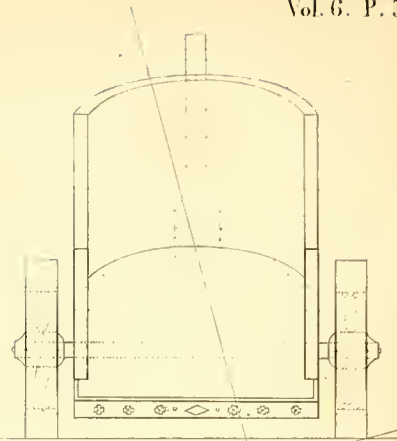
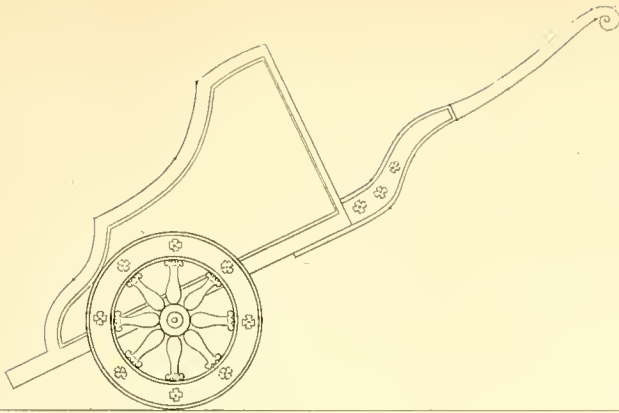

Elevations Géométrales.

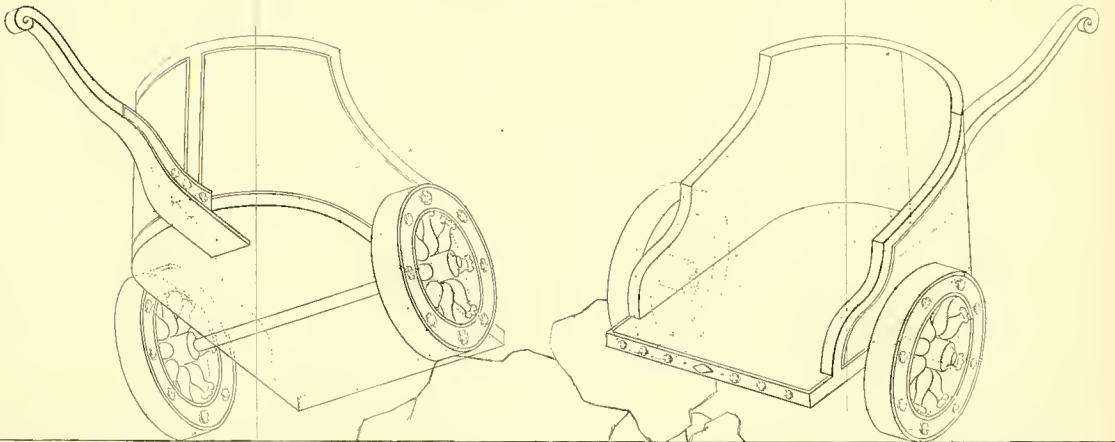

Dessiné par C. Chollot.

Gravé par J. A. Allais.



Représentation Perspective.

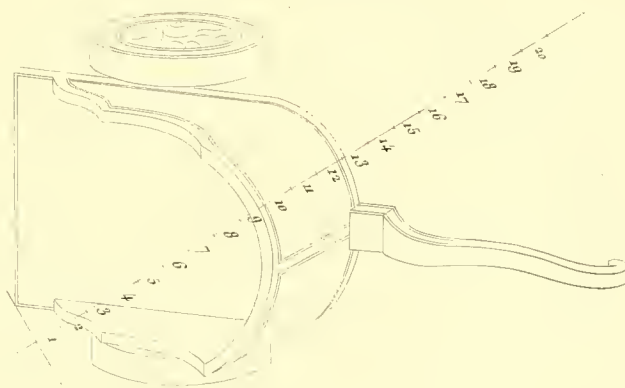

5 D

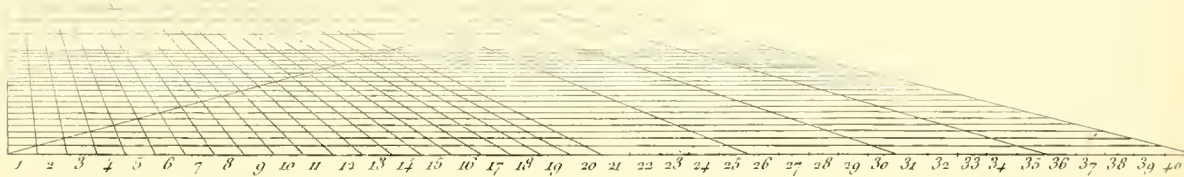

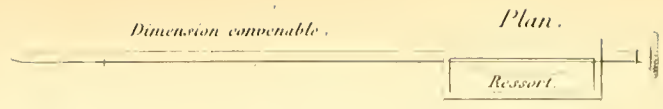

Profil.

507.

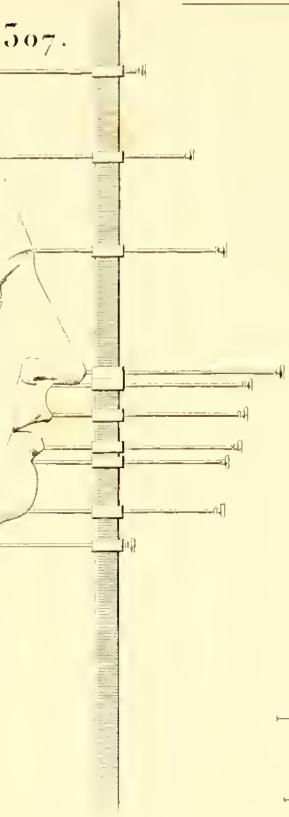

508.



509.

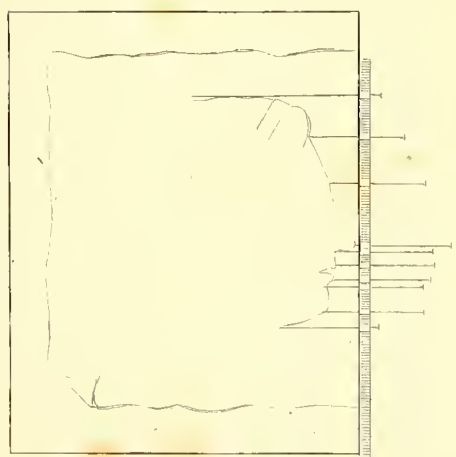

Boucard F. d'instruments graphiques.
Place du Palais de Justice, N° 29



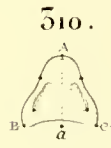
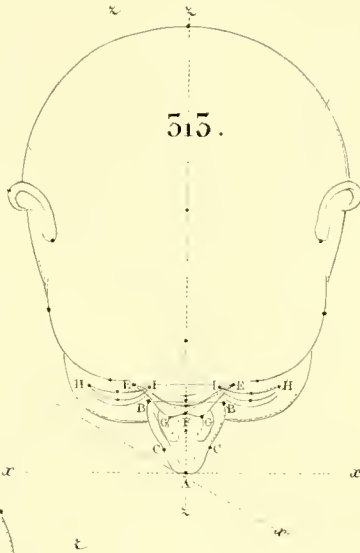
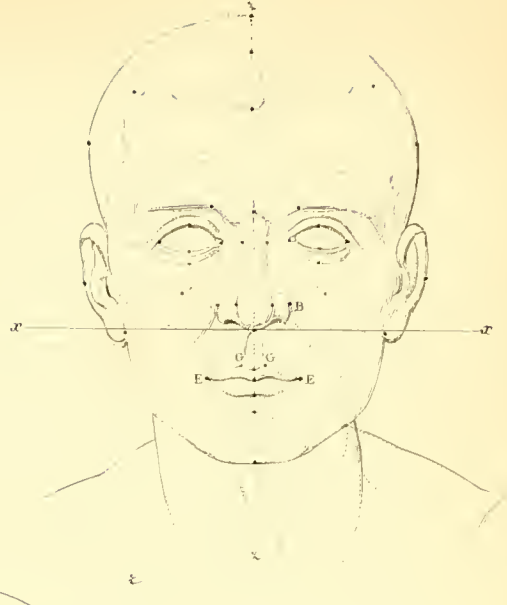

514.

autre aspect.

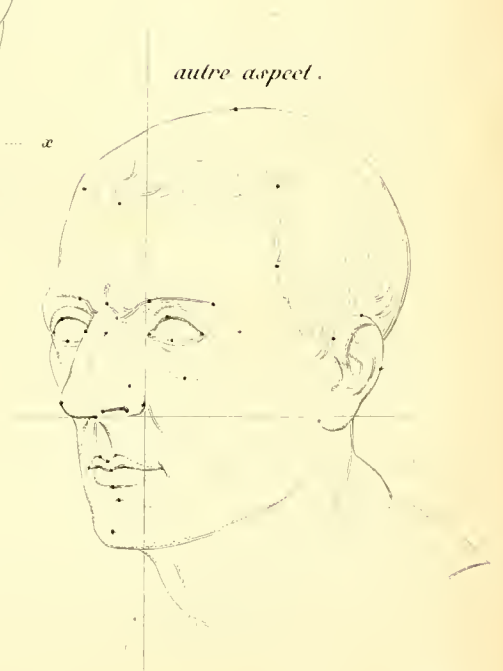

Dessiné par C. Chollot.

Gravé par J.-A. Allais.





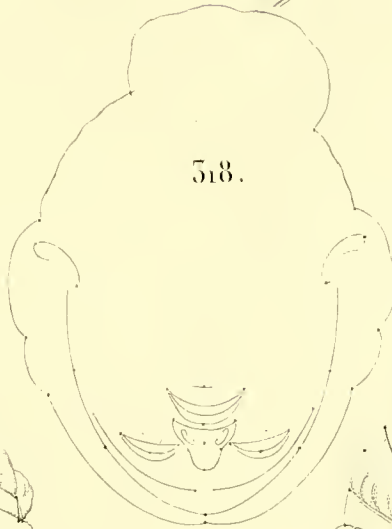

519.

520.



Dessiné par C. Chollot.

Gravé par J. A. Allard.





524.

525.
autre position.



Dessiné par C. Chollat.

Gravé par J.A. Allard.



Géométral

concocté en

Perspectif.

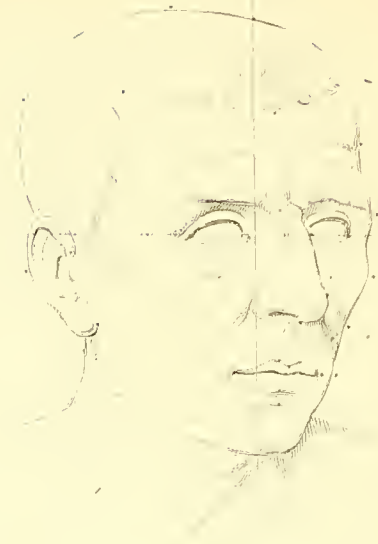

Plan.

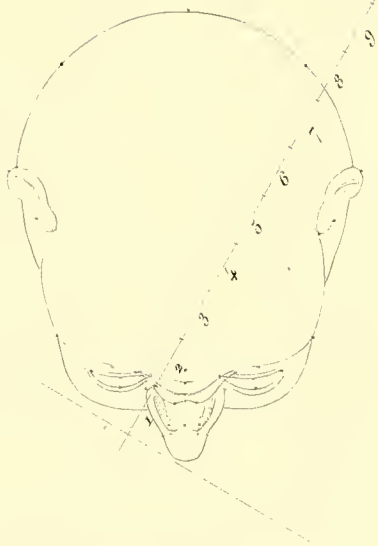

Distance 8 Pieds.

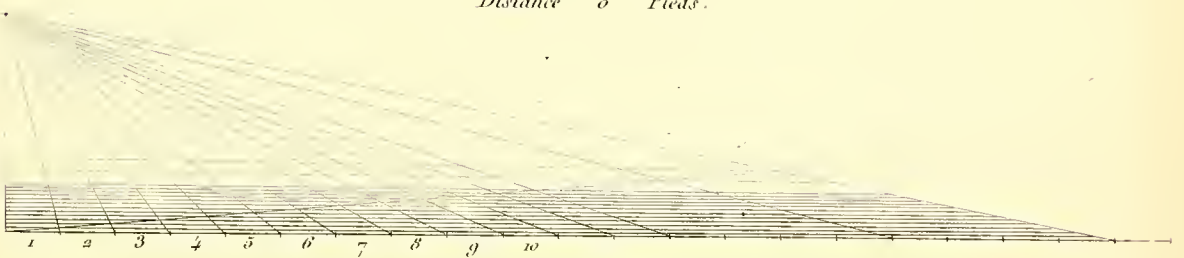

Dessiné par C. Chollot.

Gravé par J.-A. Allais.





526.

Vue Perspective du Tableau Orthographique

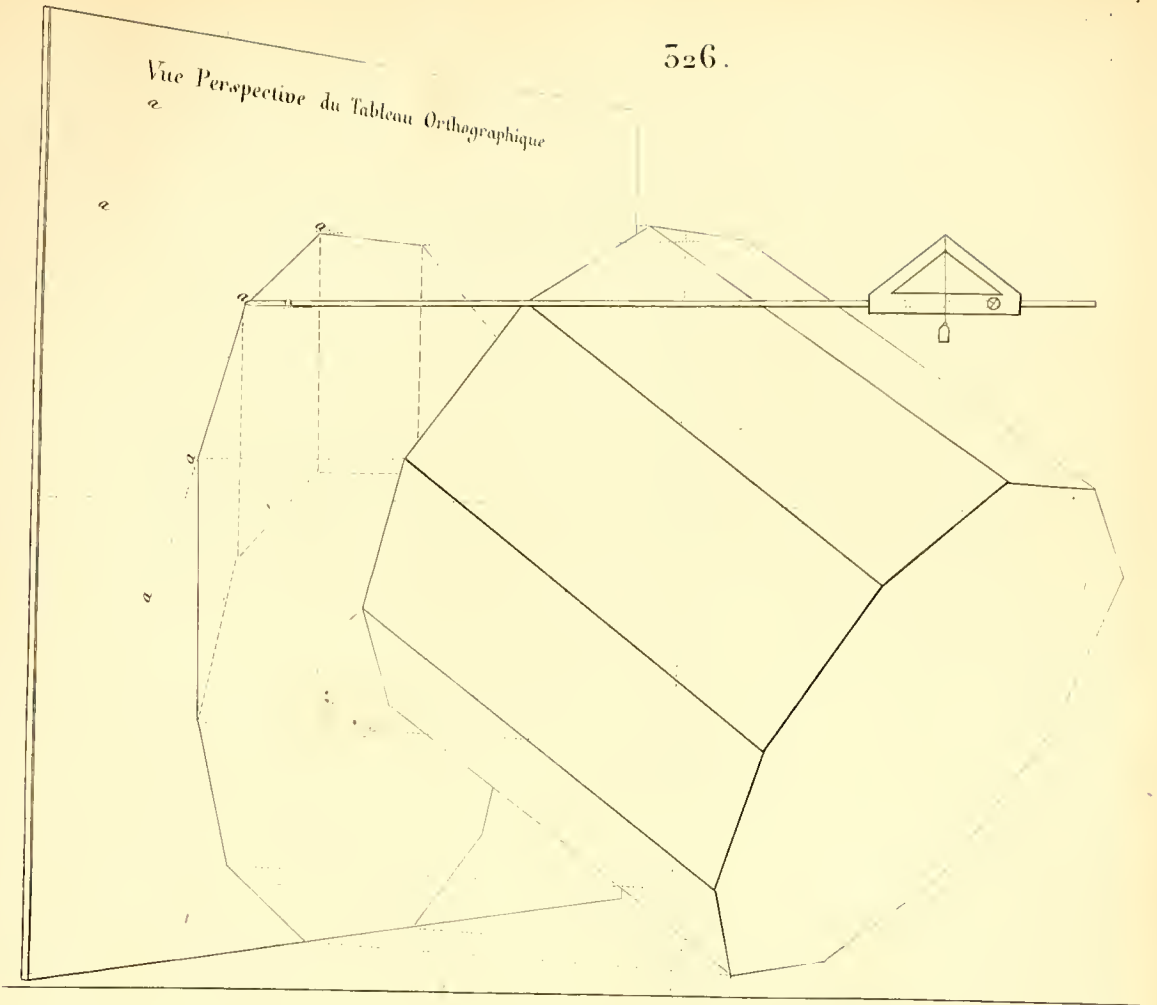

Autre Exemple.

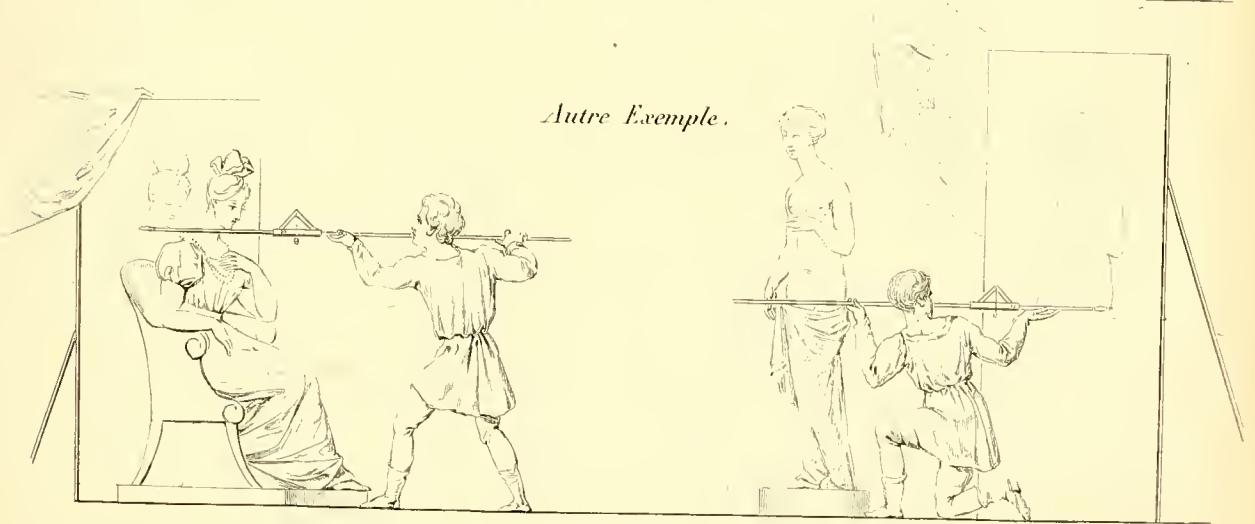

529.



530.



531.

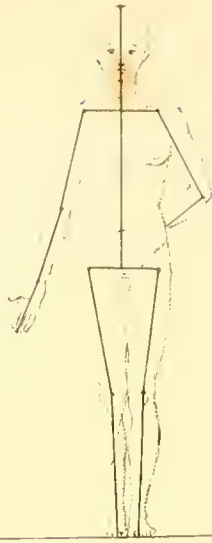

Esquisse.

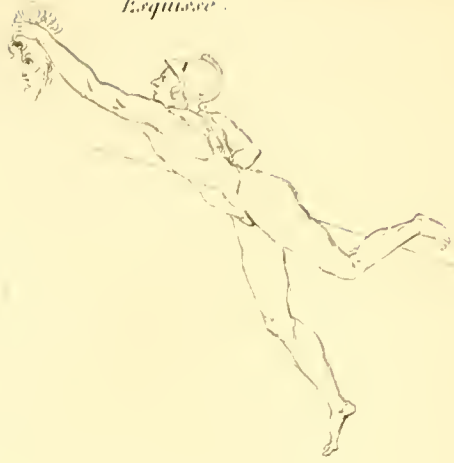

532.



533.



535.

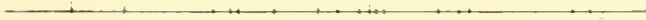

534.

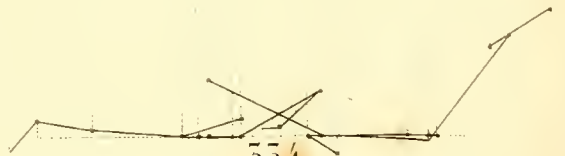



336.

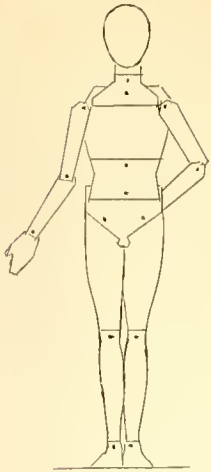

337.



338.

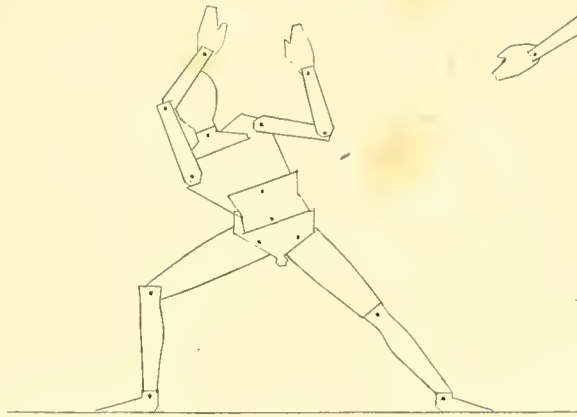

339.

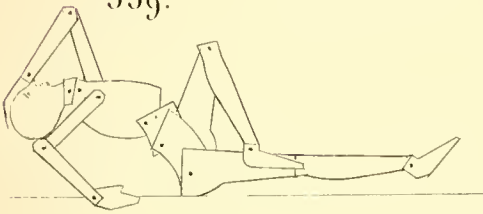

340.

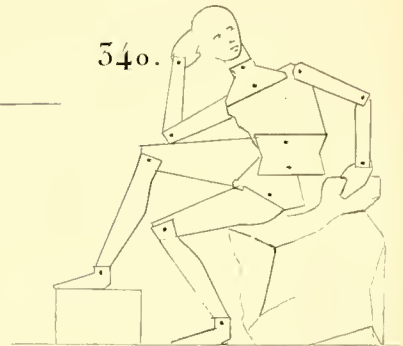

Vol. 6.

341.

P. 564.

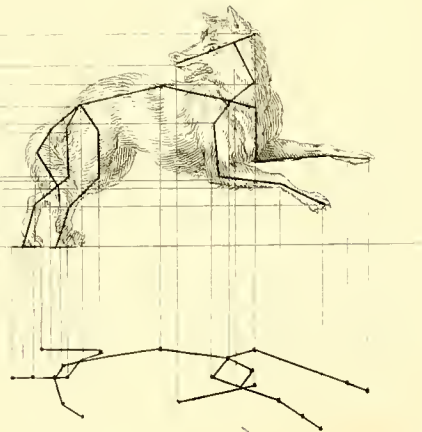
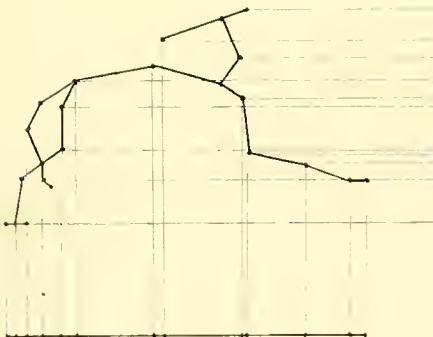



542.

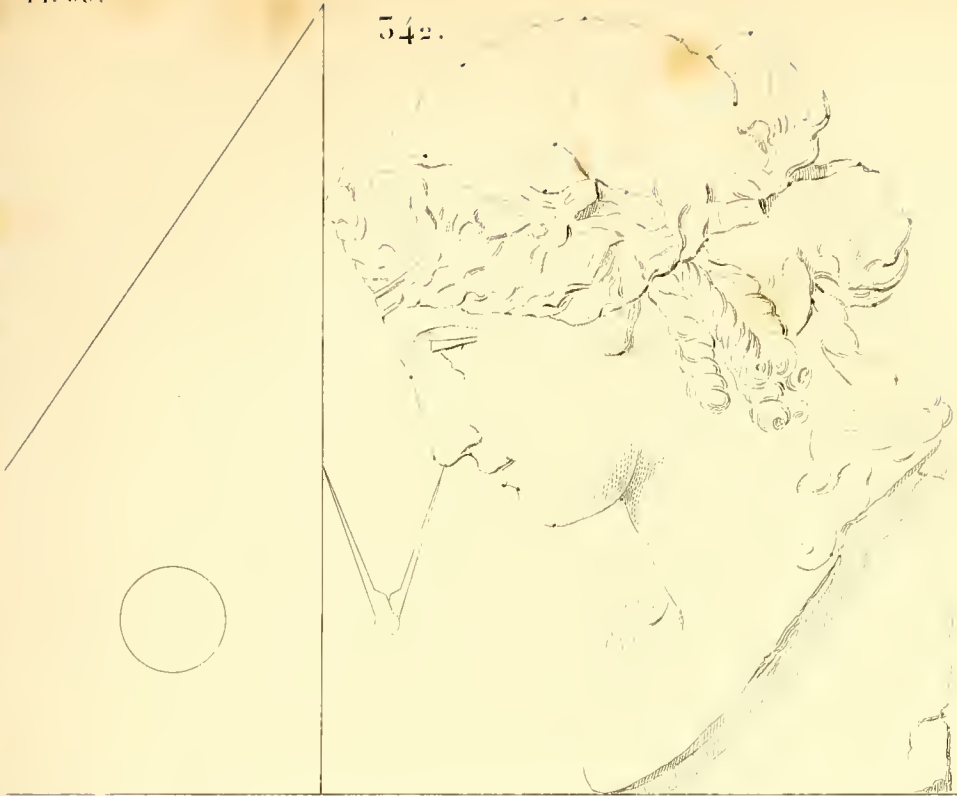

545.

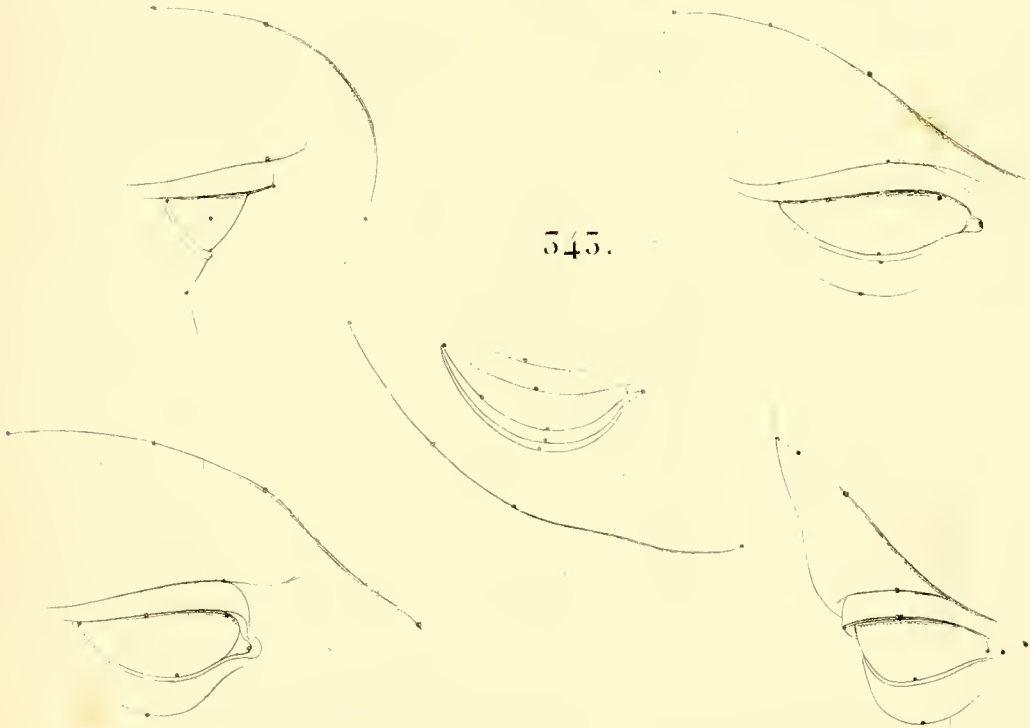

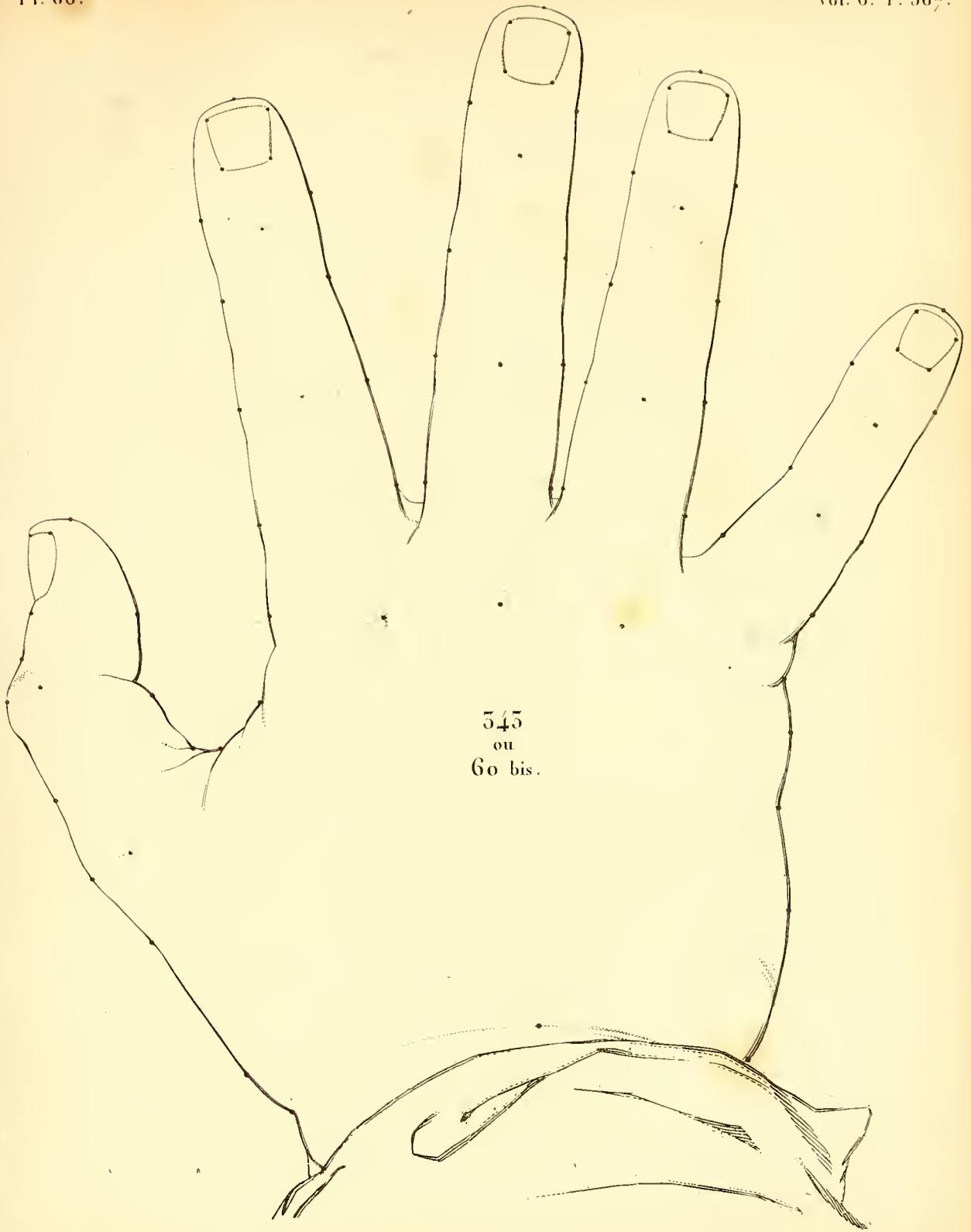

545
ou
60 bis.



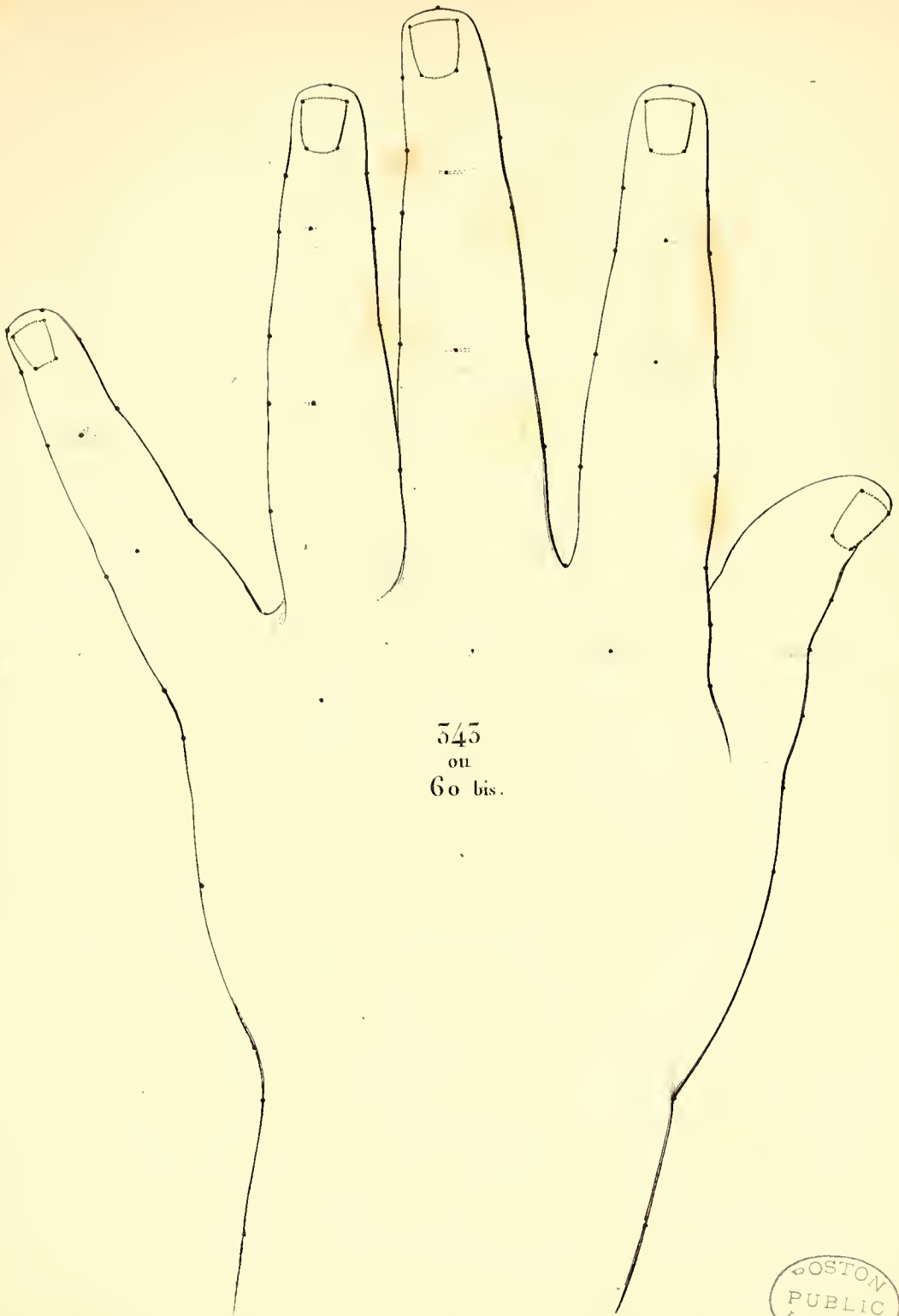

545
ou
60 bis.



345.

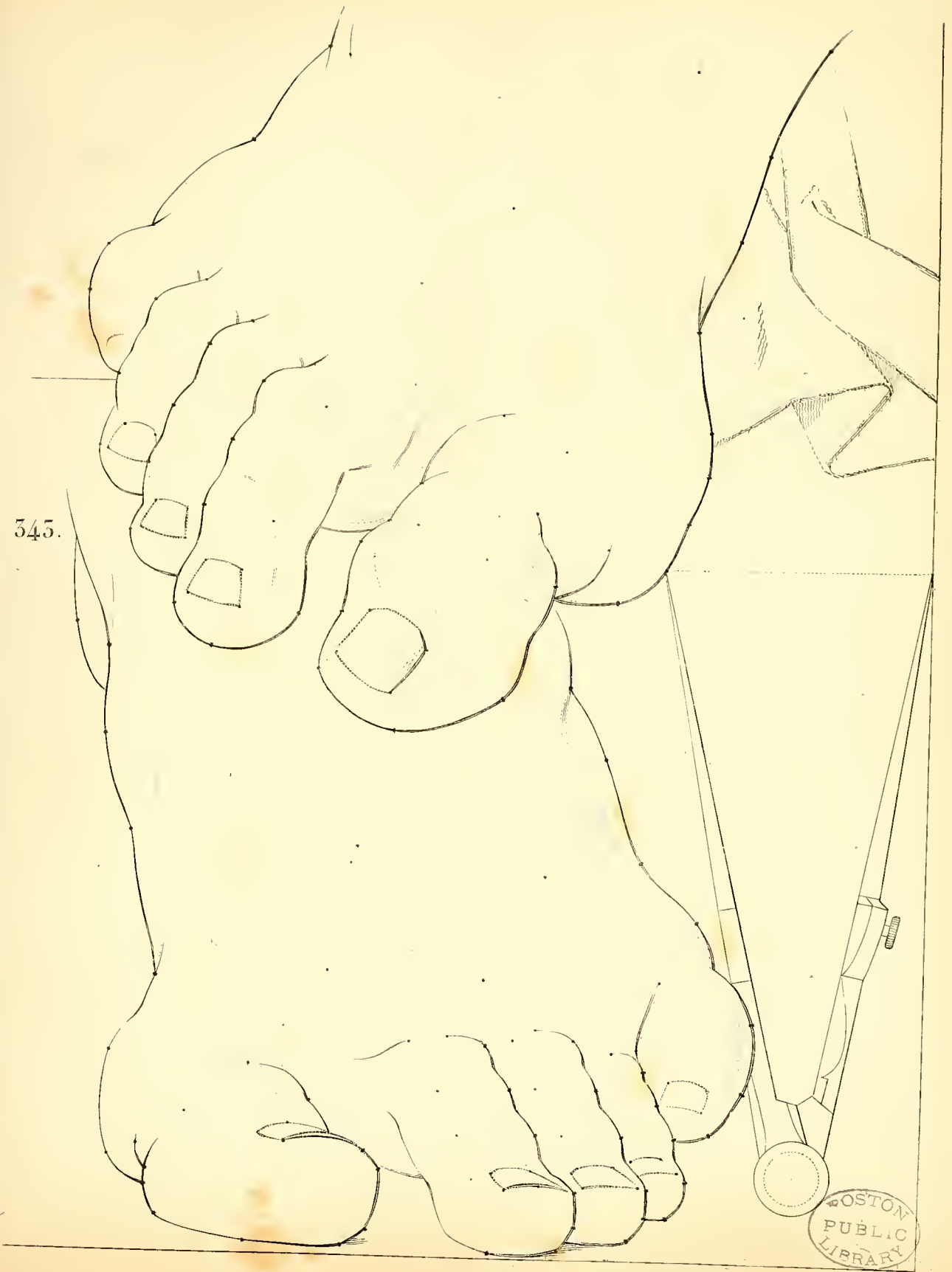

BOSTON
PUBLIC
LIBRARY



545.



546.

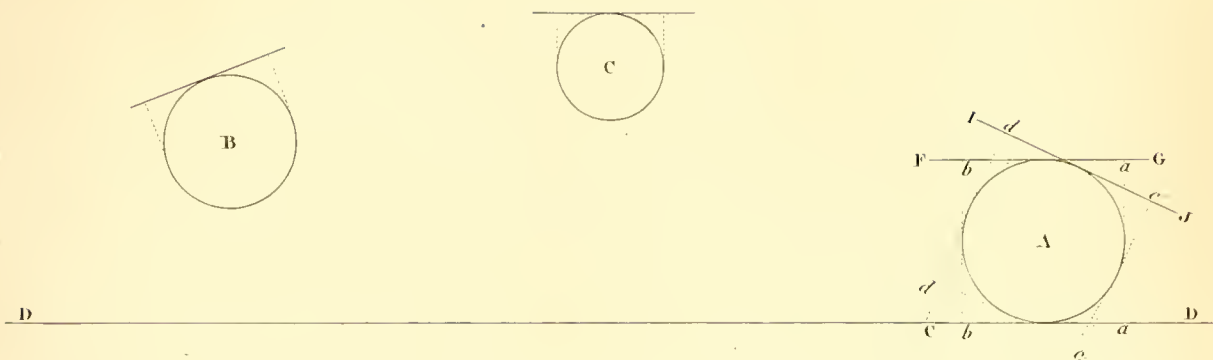

544.

Vol. G.

P. 591.

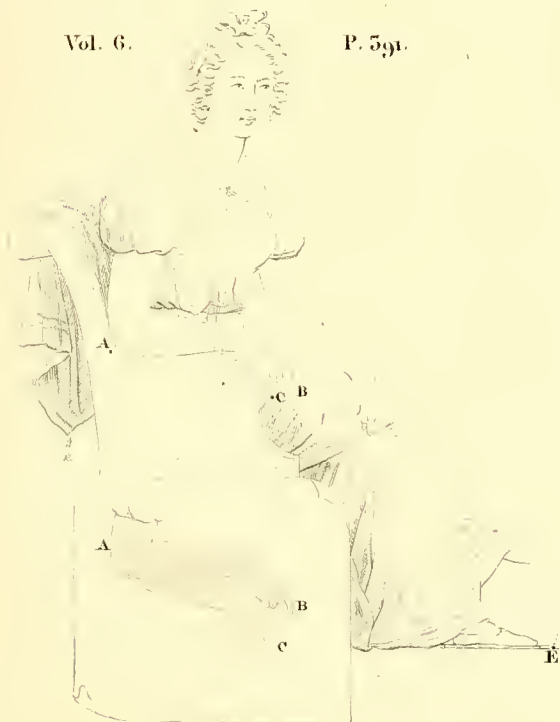

b

a



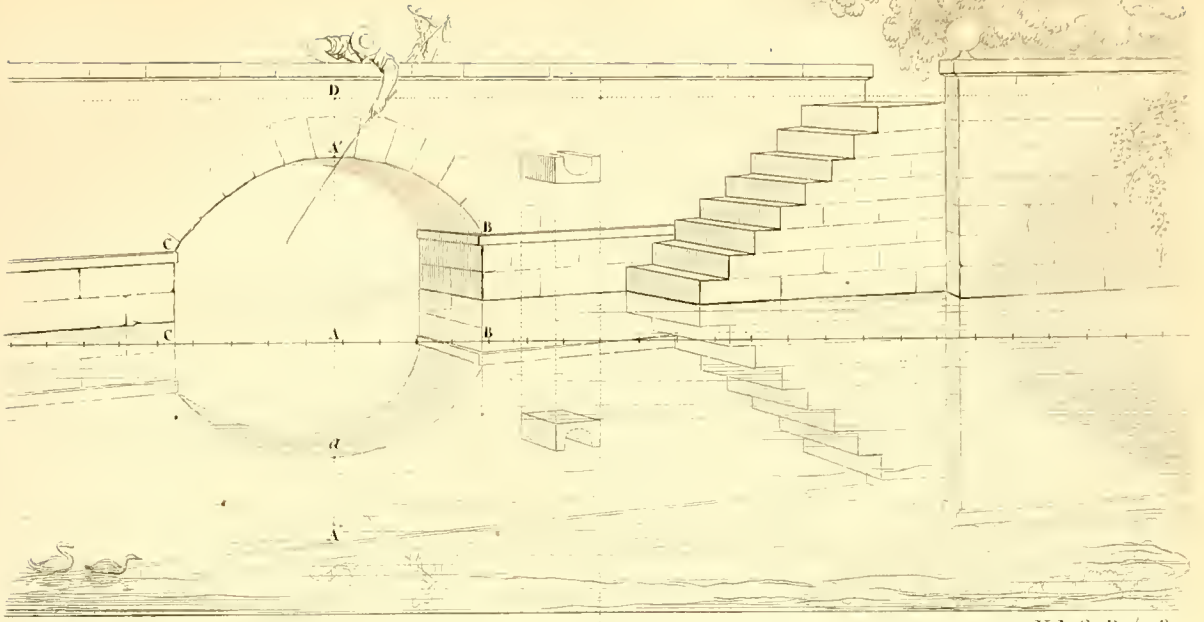

Vol. 6. P. 408.

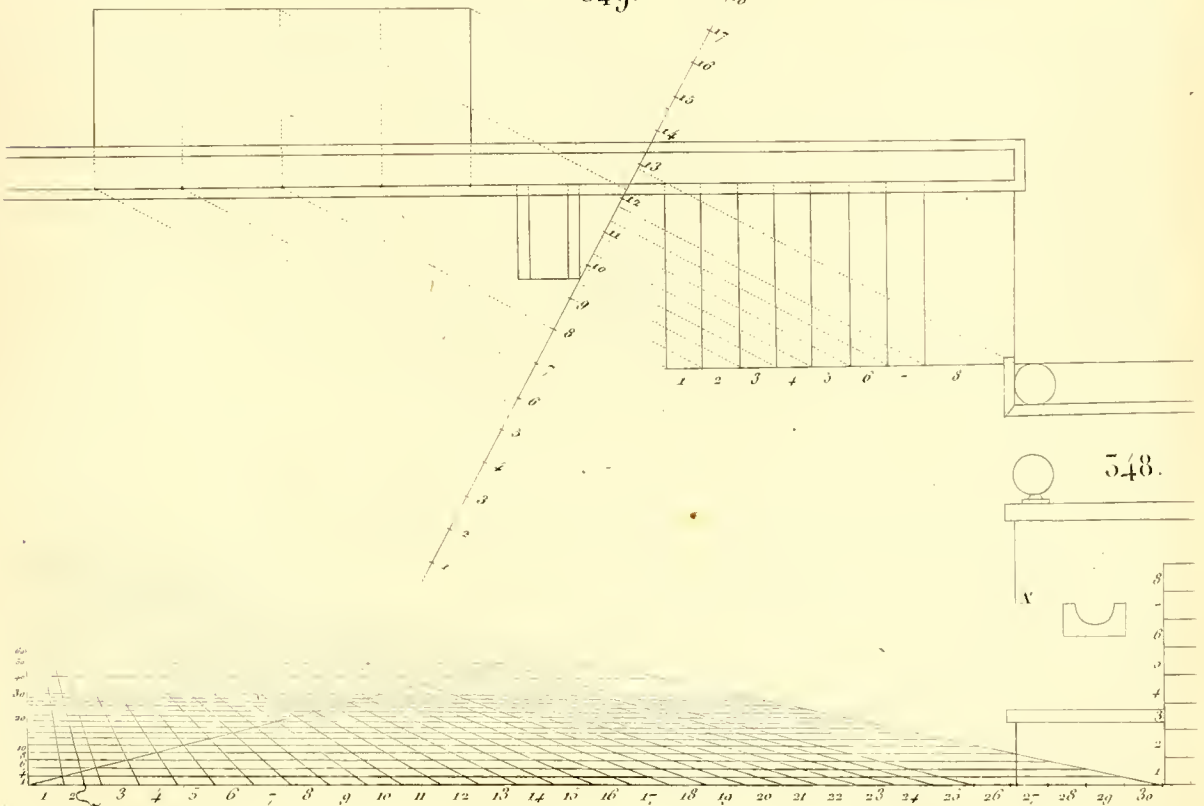

550.

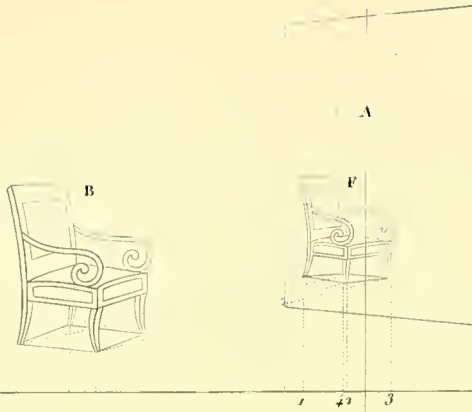

551.

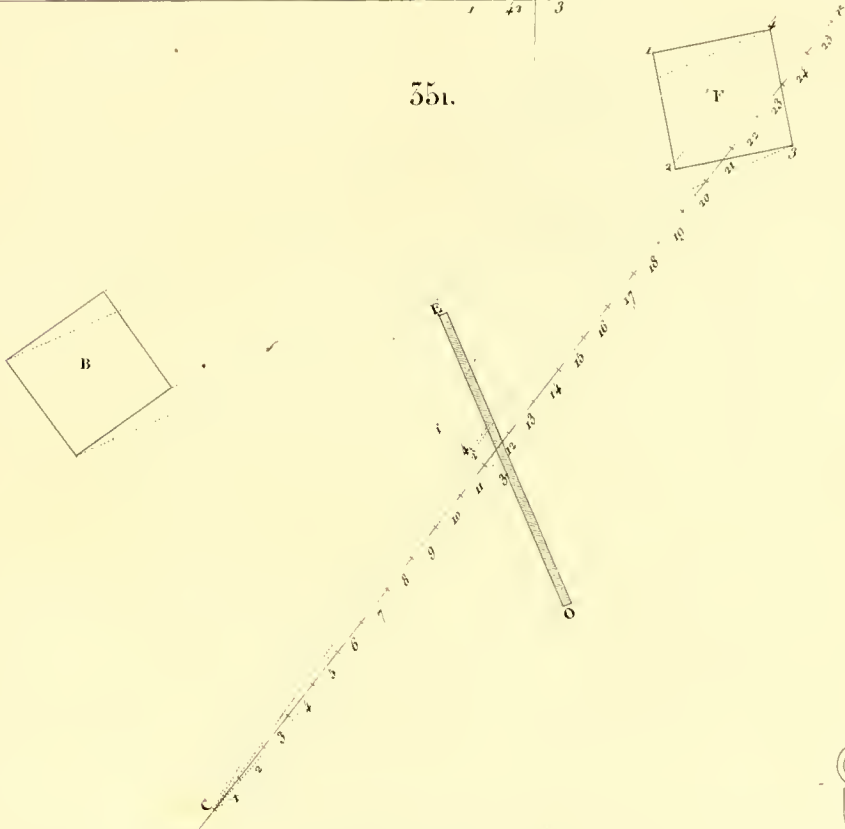

552.

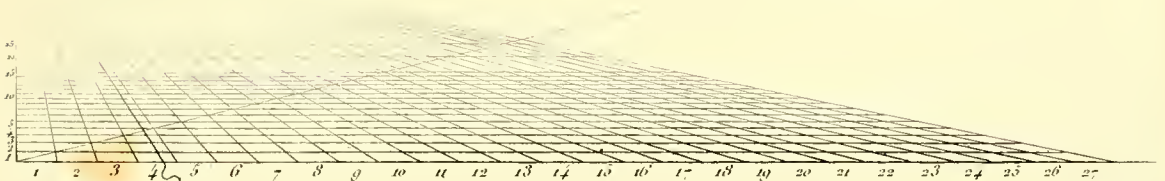
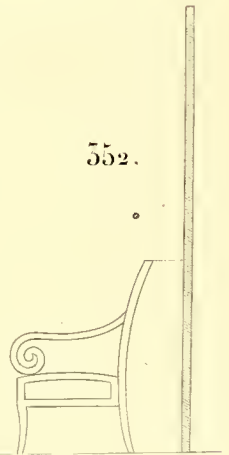

Vol. 6. P. 40.

357.

Vol. 6. P. 420.

355.

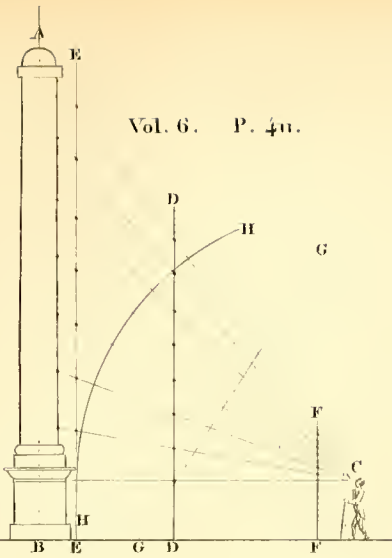

356.

A

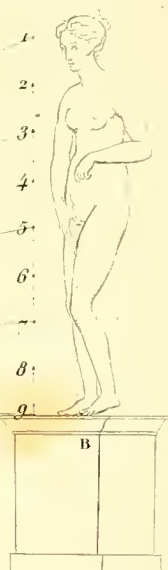

354.

Vol. 6. P. 413.



Vol. 6.

357.

358.

P. 462.

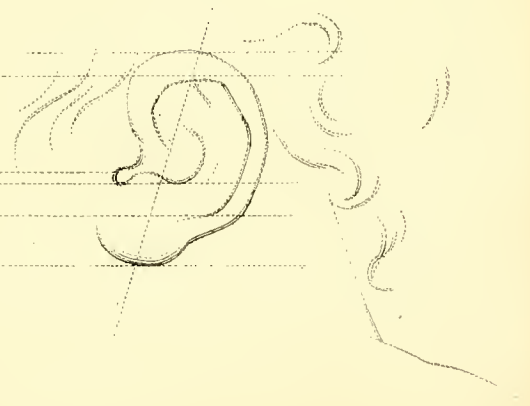
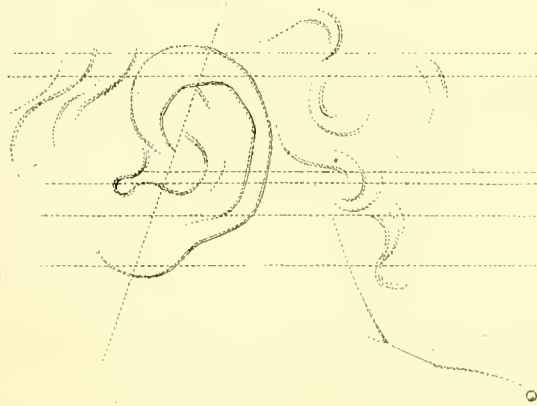

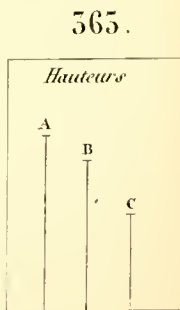
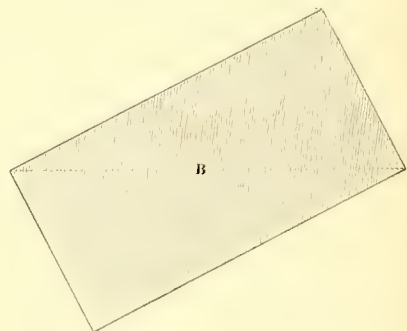
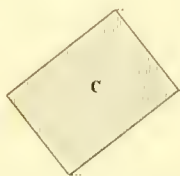

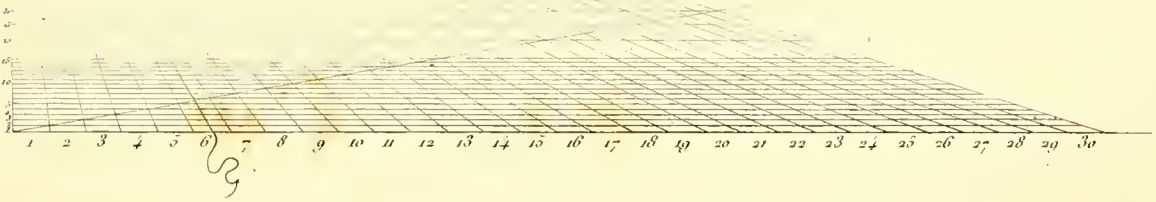
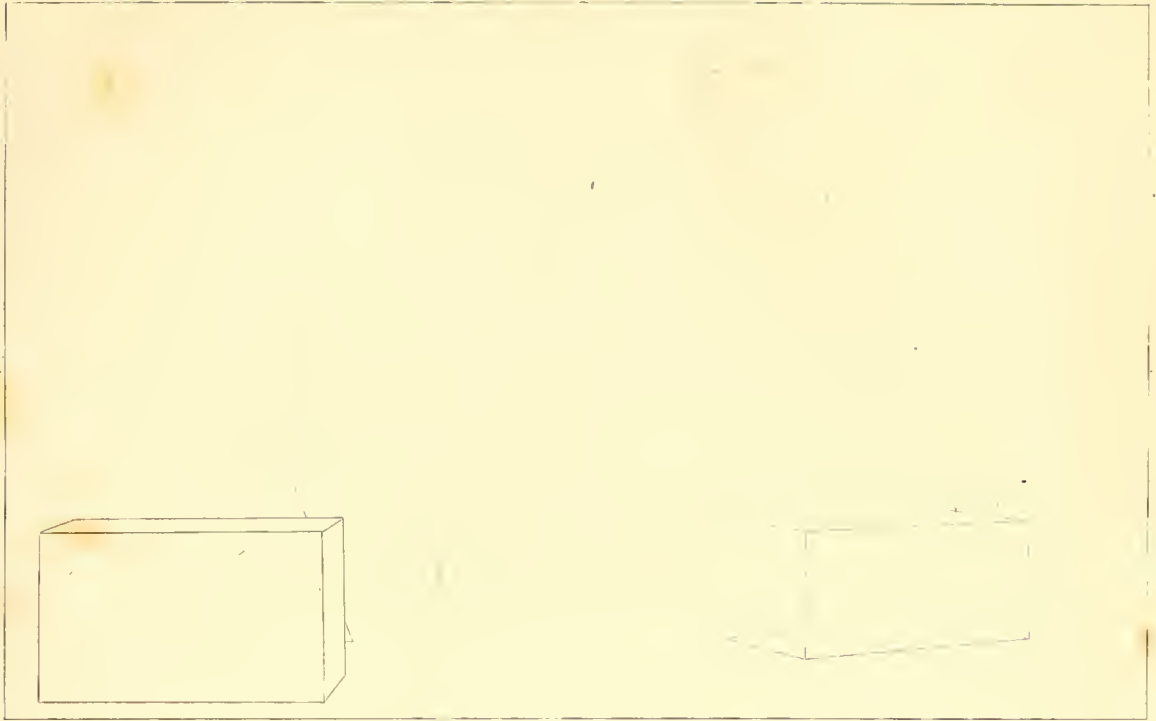



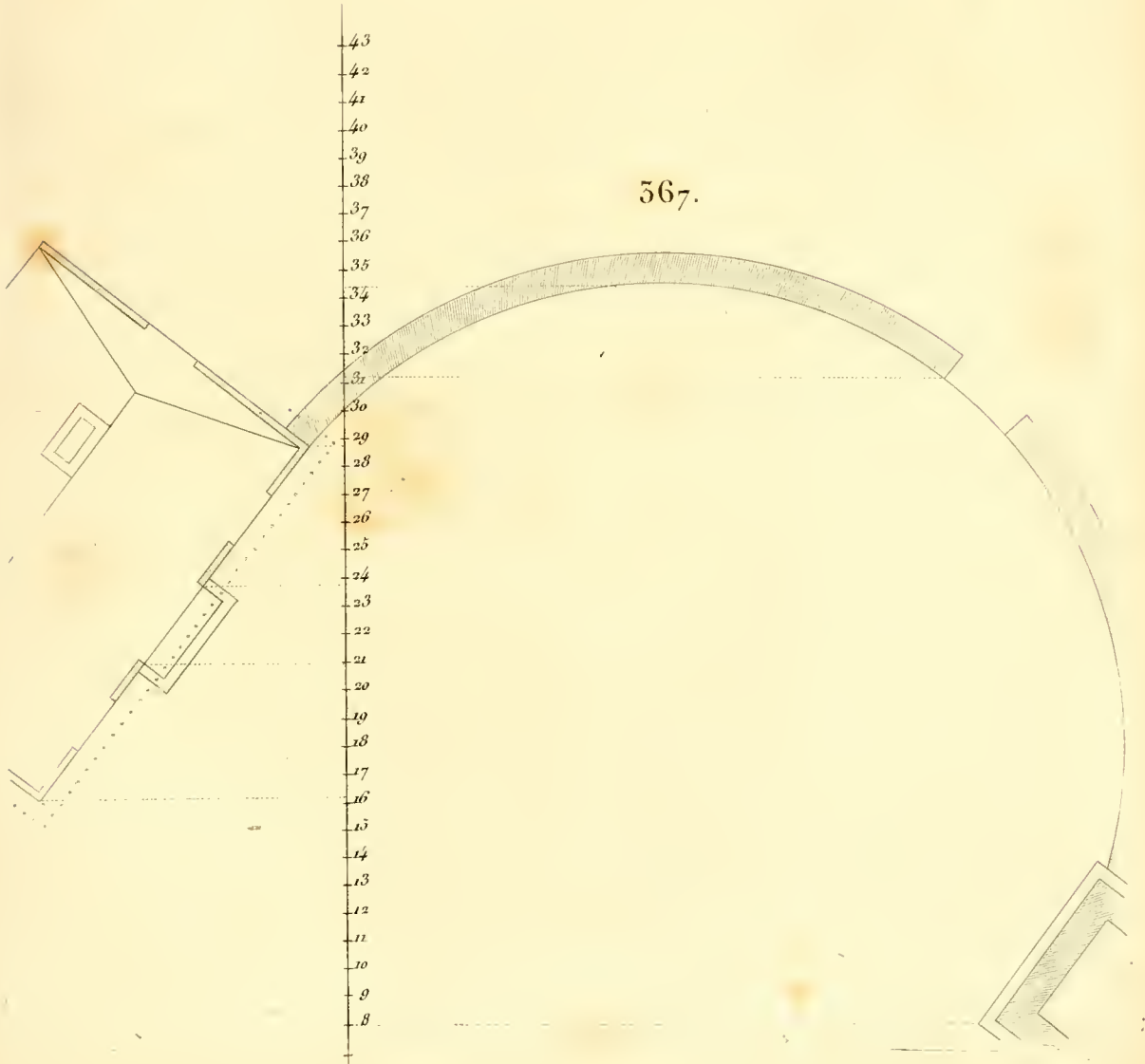

367.





369.



368.

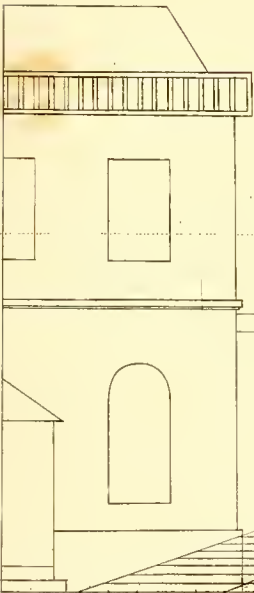

366.





570.

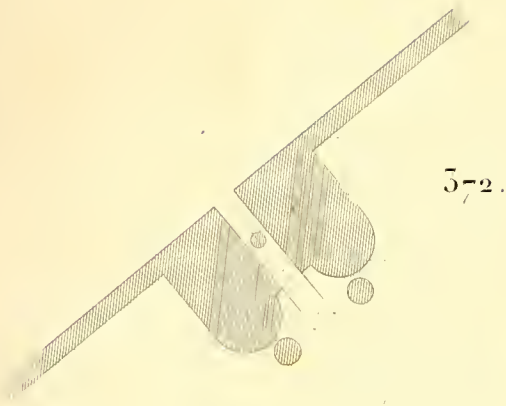

572.

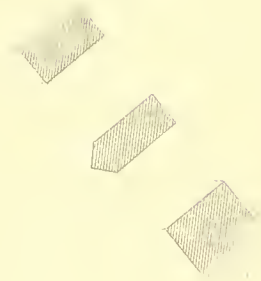
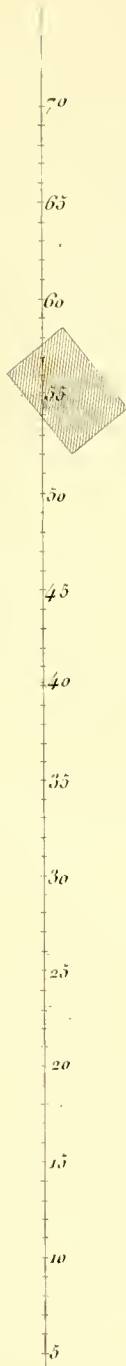

Plan réduit a moitié.





374.



375.

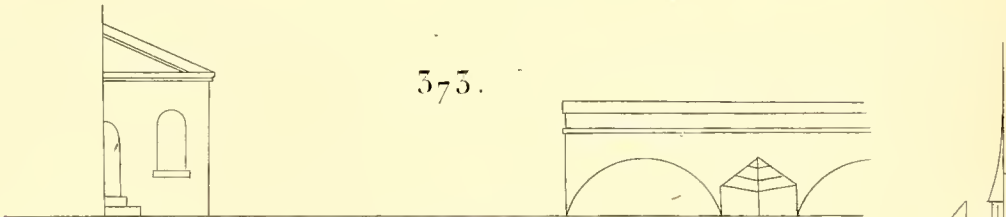

371.

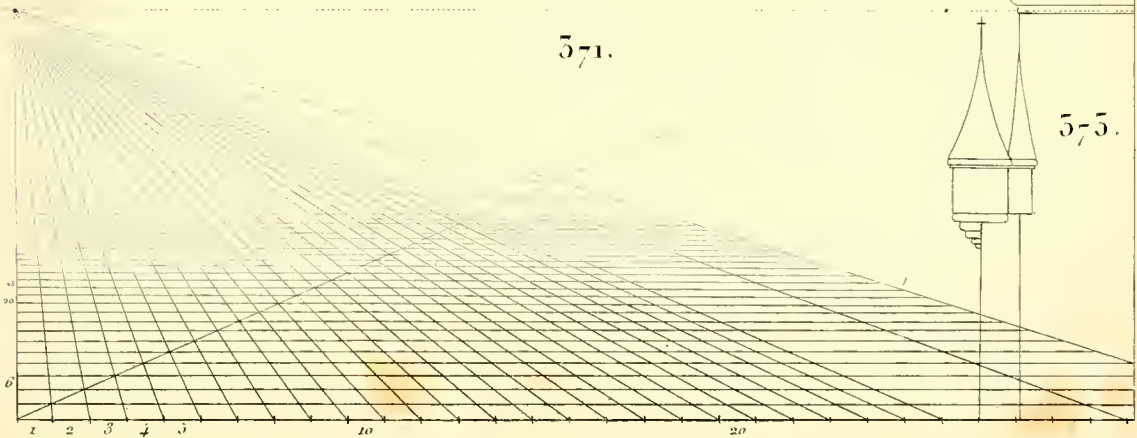

375.



575.



579.

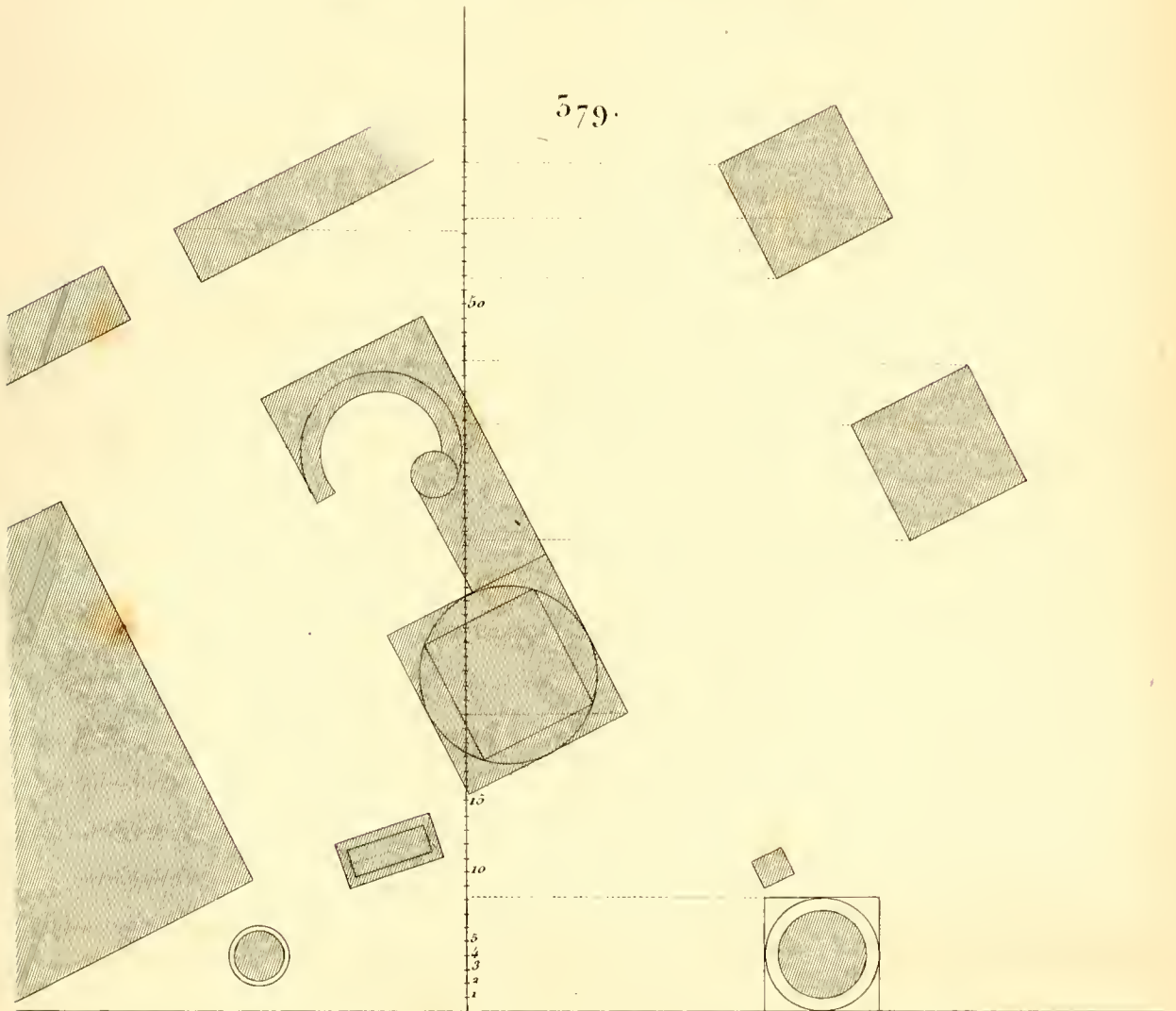



578.

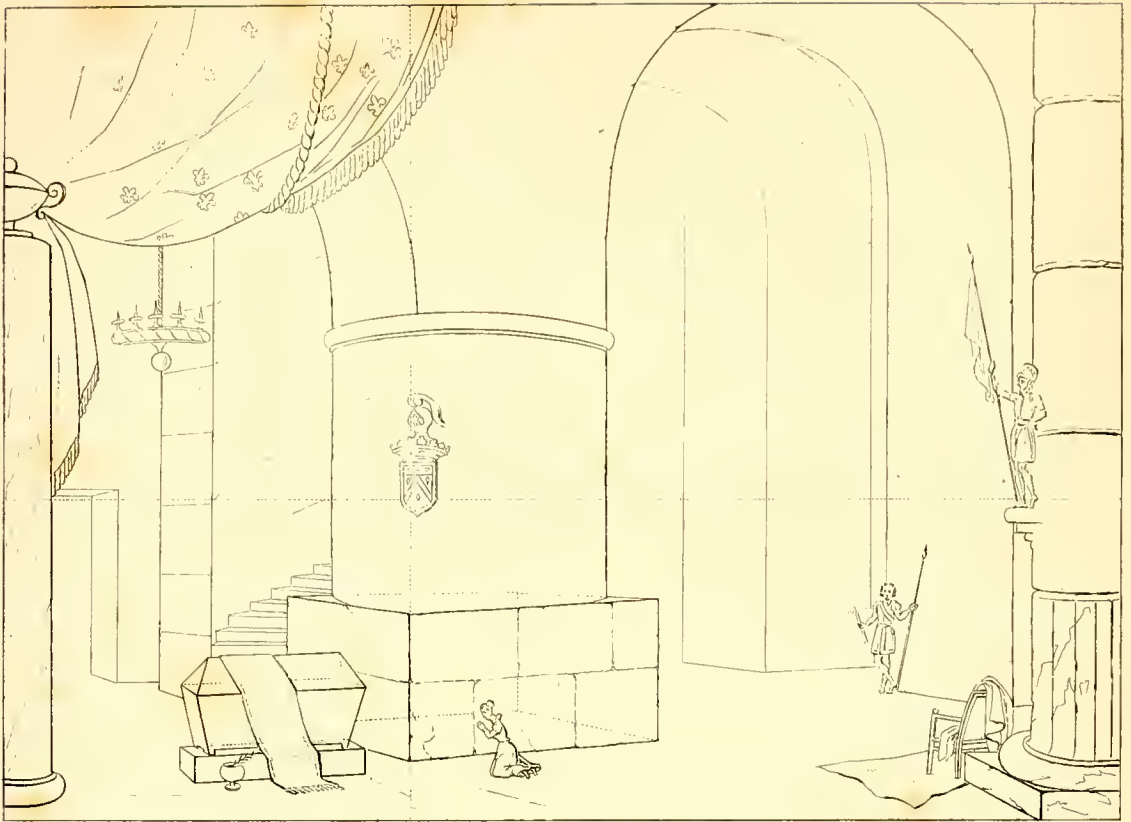

576.

577.
Hauteurs.

Pilier rond . . .	12 Pieds
Base du pilier . . .	6 —
Tombau	4 — 1/2
Voutes	36 —

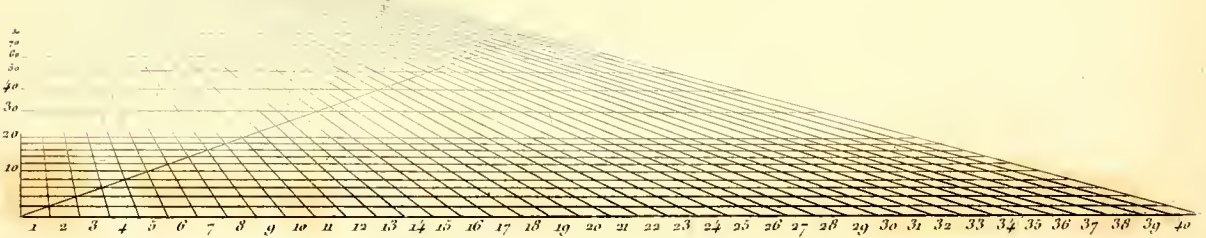

Dessiné par C. Chollot.

Gravé par J. Allais.



580.

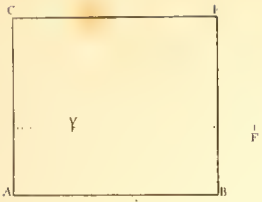

582.

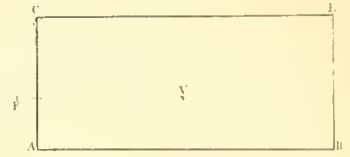

381

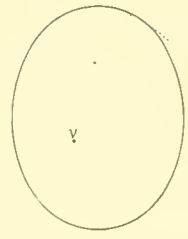

583.

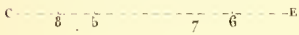
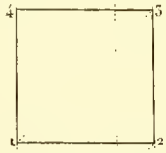
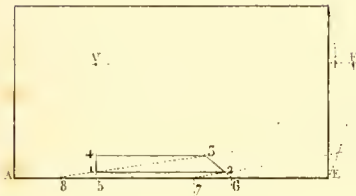

584.

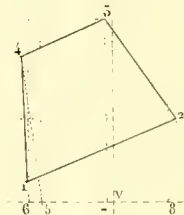
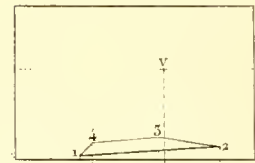

585.

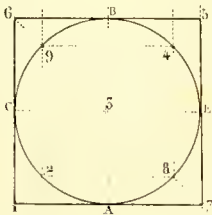
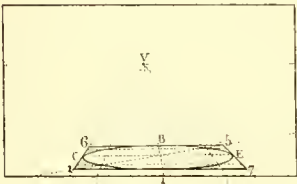

586.

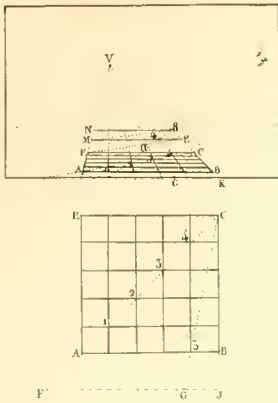

587.

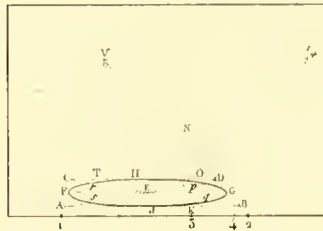

588.

Vol. 6.

P. 489.

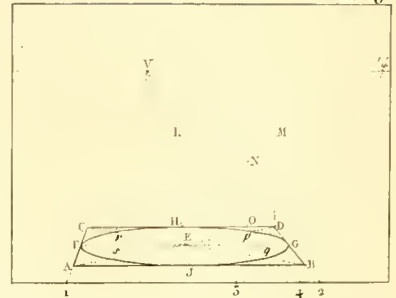

589.

Vol. 6.

P. 490.

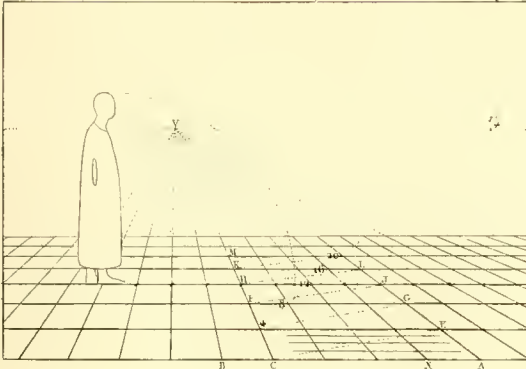

590.

Vol. 6.

P. 491.

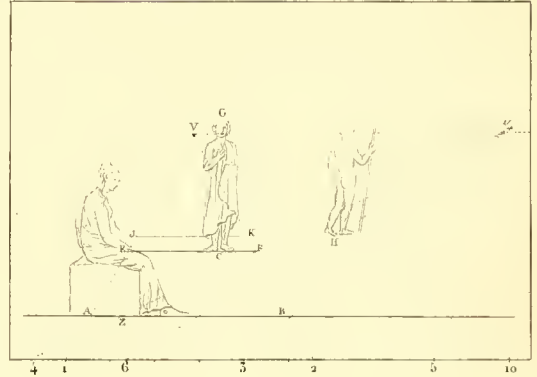

591.

Vol. 6.

P. 492.

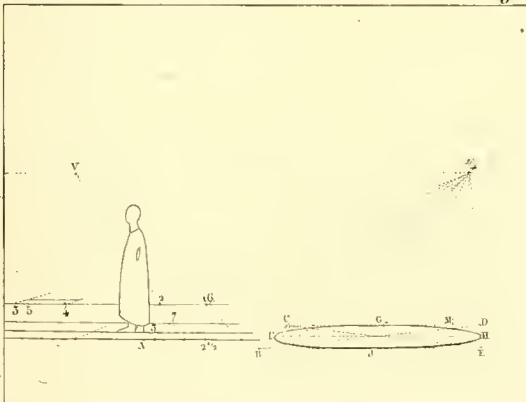

592.

Vol. 6.

P. 494.

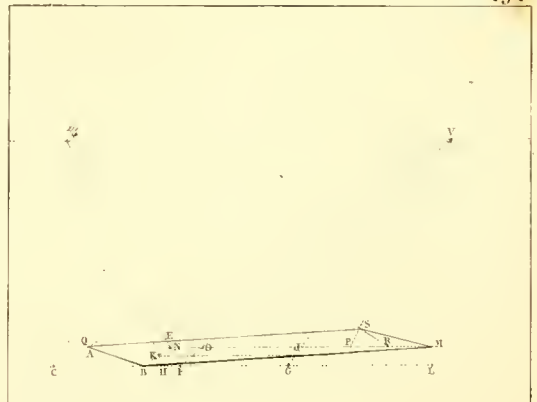

395.

Vol. 6.

P. 495.

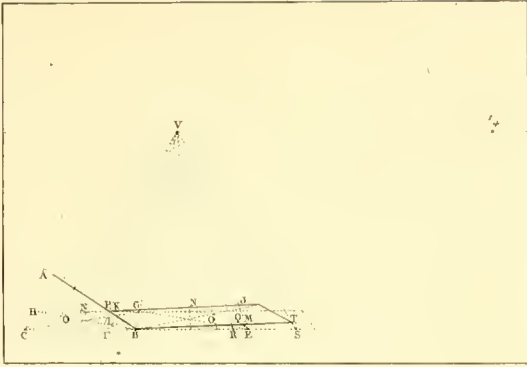

394.

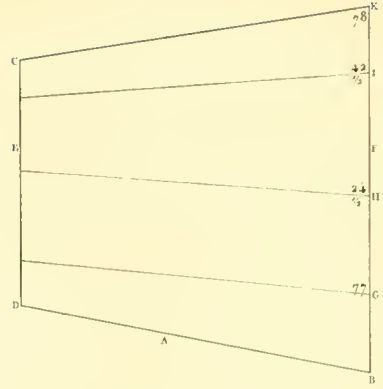

395.

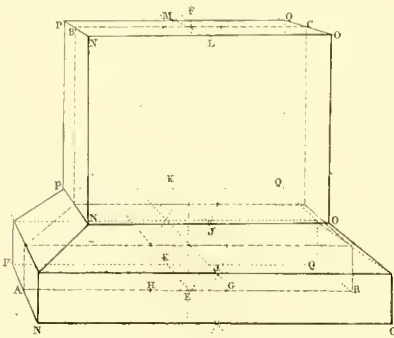

396.

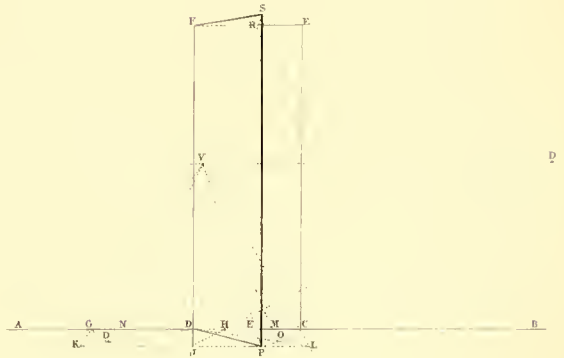

397.

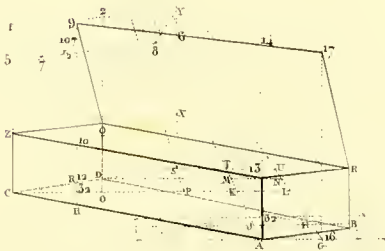

400.

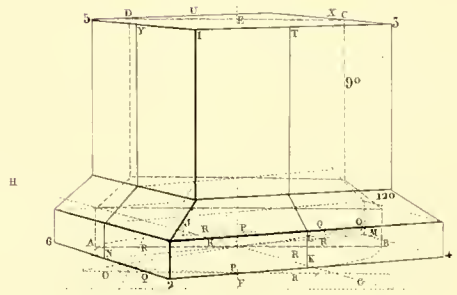

598.

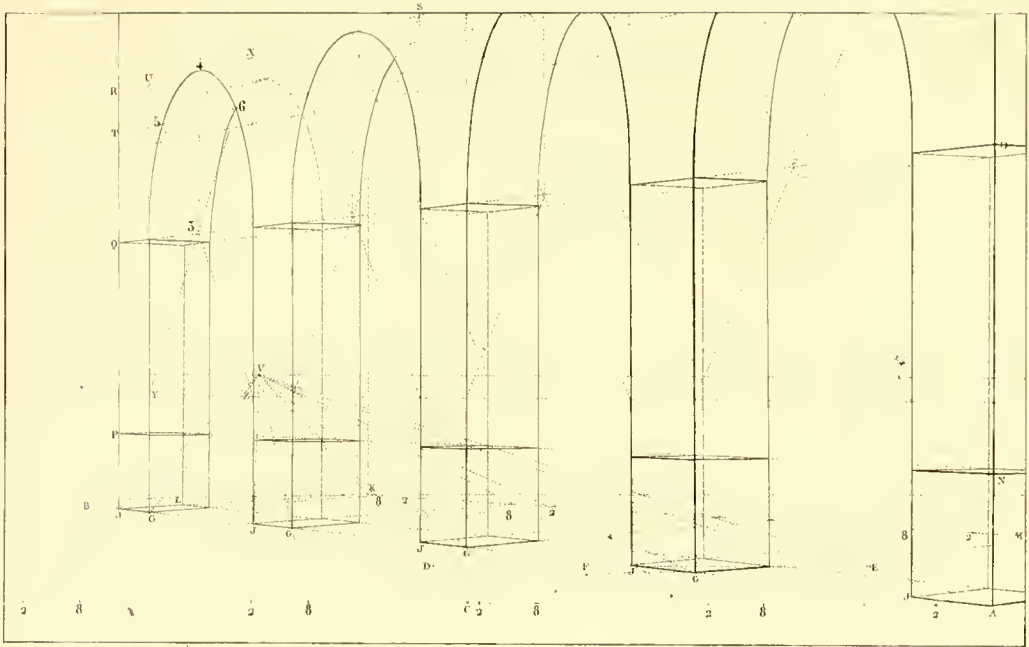

599.

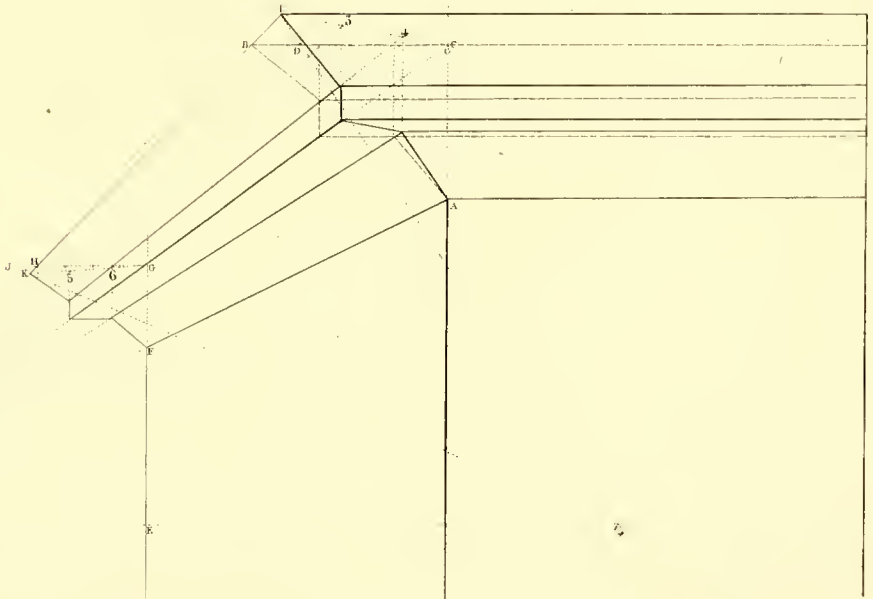



401.

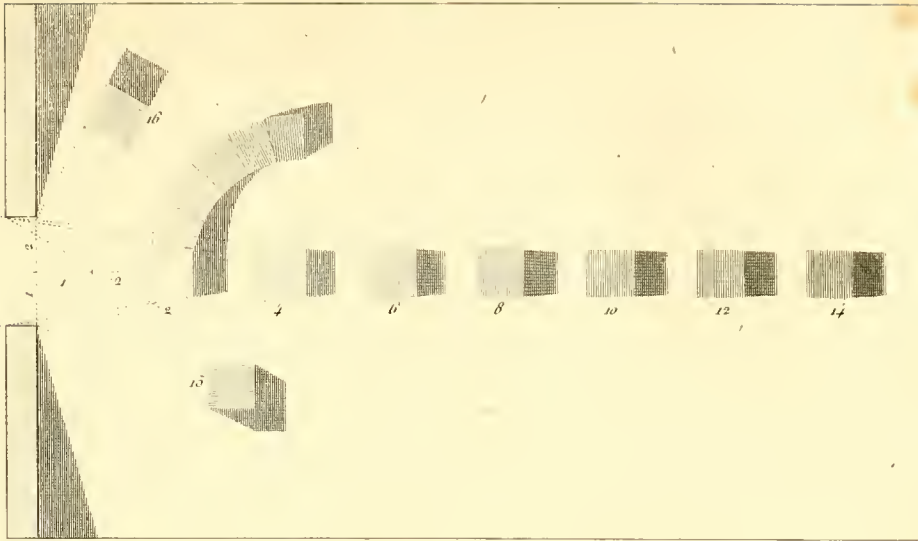

402.

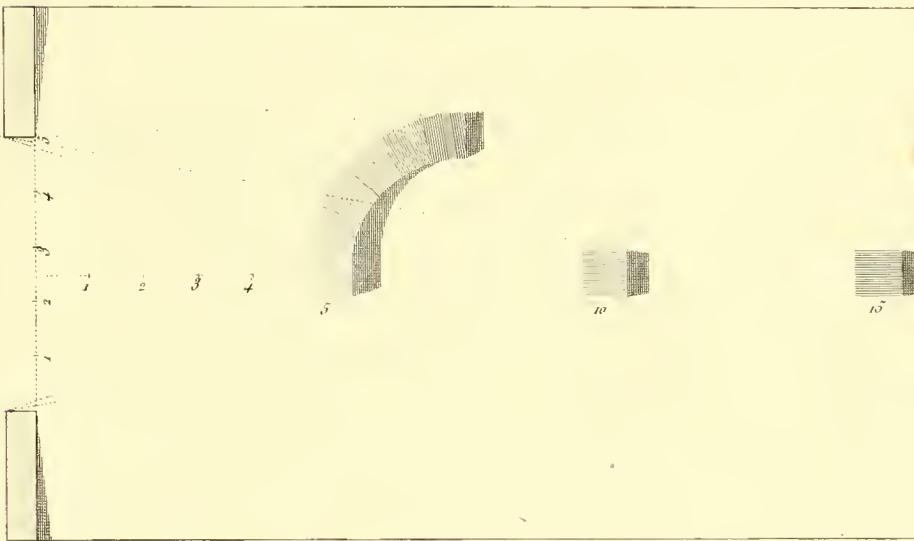

405.

Vol. 7.

P. 45.



Vol. 7.

P. 58.

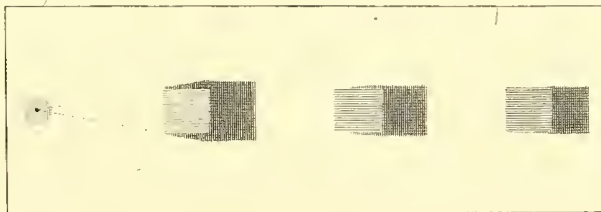

Vol. 7.

P. 45.



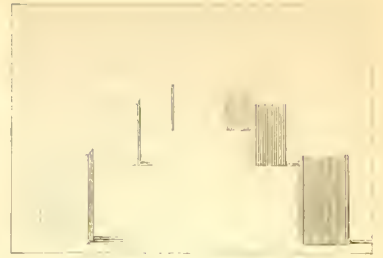
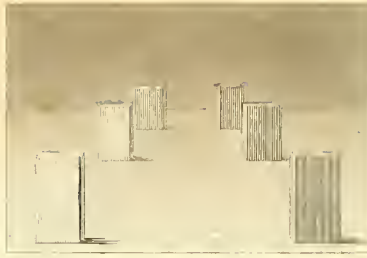

407.



408.

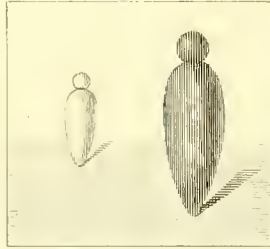

409

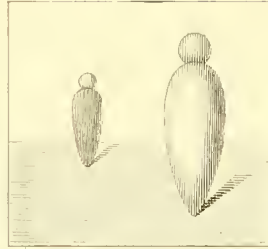

410.

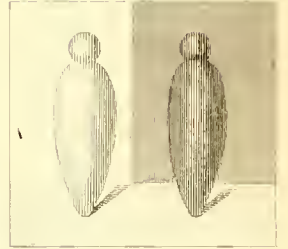

411.

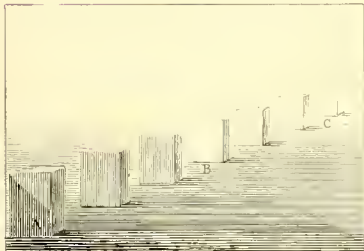

412.

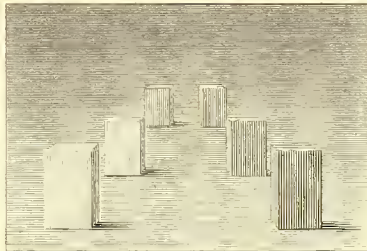

415.



414.



415.



416.

Vol. 7.

P. 53.

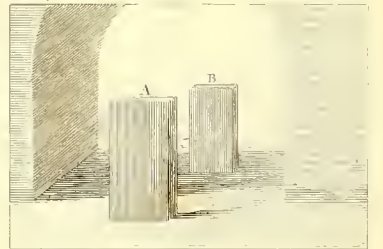

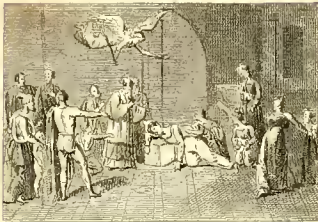

Dessiné par C. Chollot.

Gravé par J. Adam.



435.



436.



437.



438.



439.



440.



441.

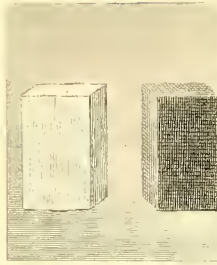

442.



443.



444.

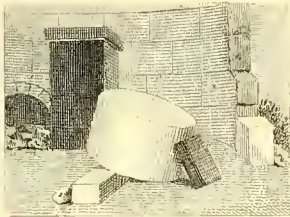

445.



446.



447.



448.



449.



450.



455.

454.

Vol. 7. P. 227
et suiv.

451.

452.



456.

457.

458.

455.



460.

465.



462.

461.



459.

466.

467.



463.

464.

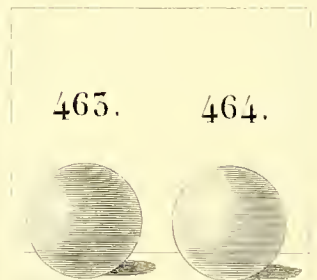

Dessiné par C. Chollot.

Gravé par J. Adam.



468.

Vol. 7. P. 255.

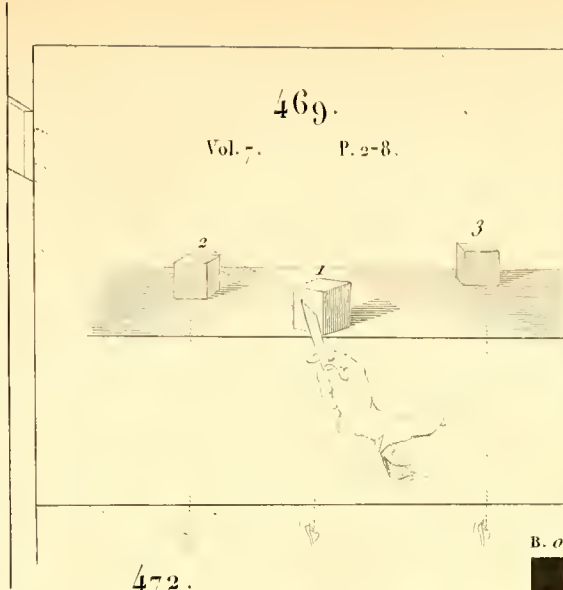

469.

Vol. 7. P. 2-8.

471.

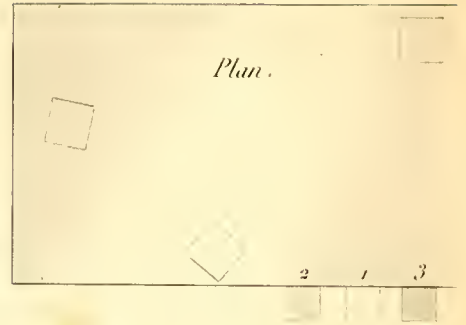

Plan.

472.

Vol. 7. P. 287.

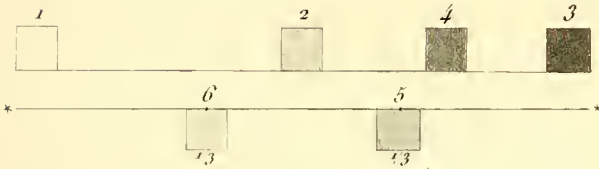

B. o

475.

Vol. 7. P. 289.

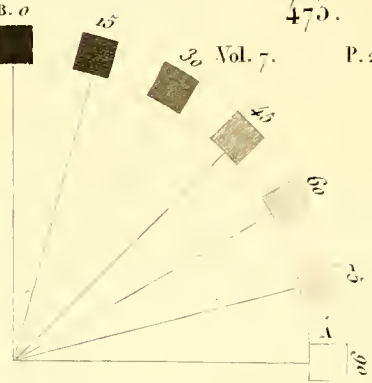

474.

Vol. 7. P. 291.

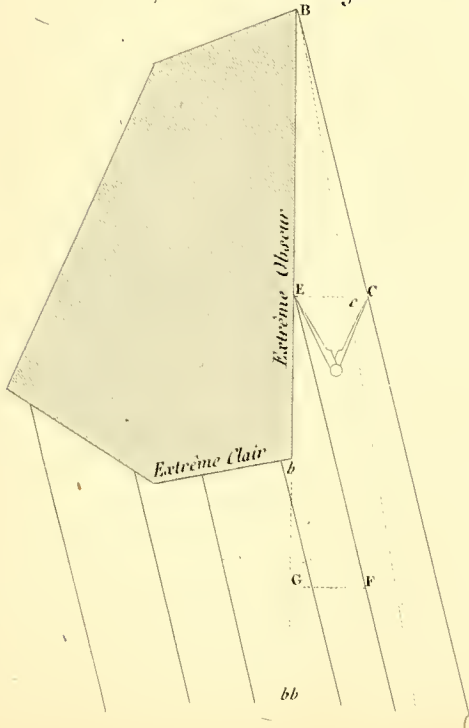

475.

Vol. 7. P. 291.



476.

Vol. 7. P. 291.

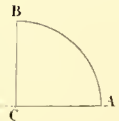

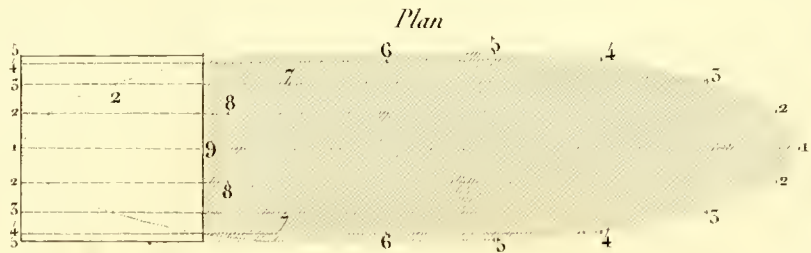
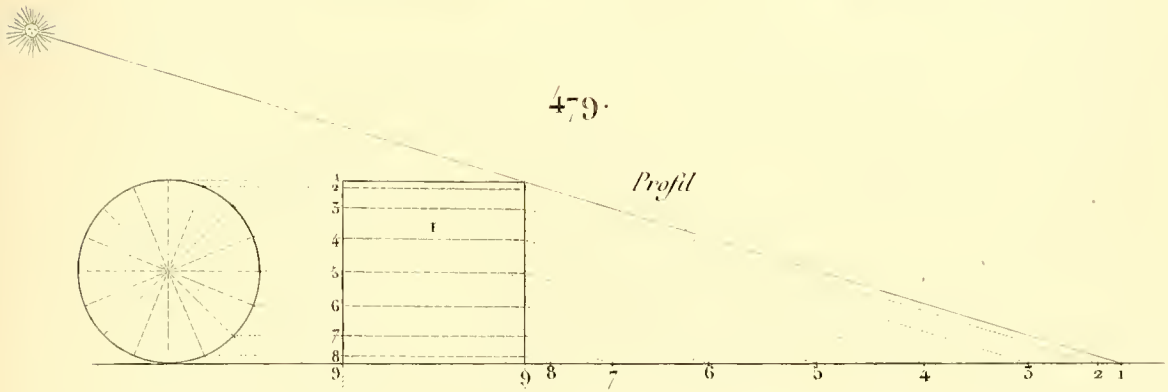
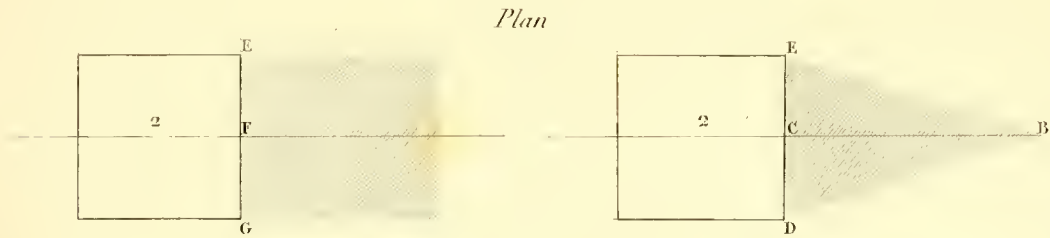
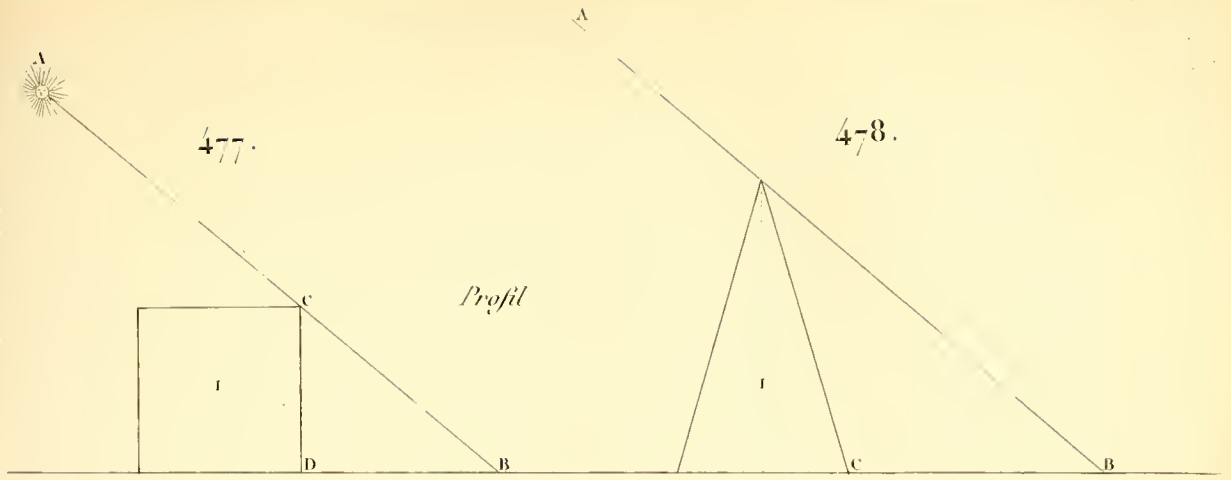

480.

Profil.

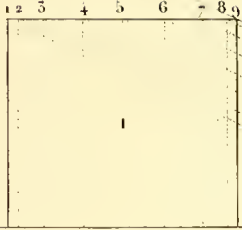

Plan .

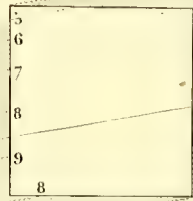
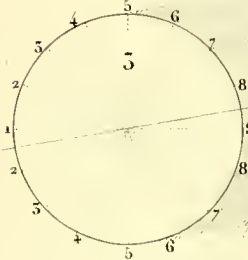

Elevation .

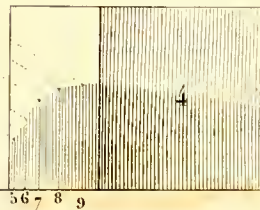
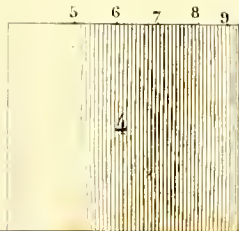

481.

Profil.

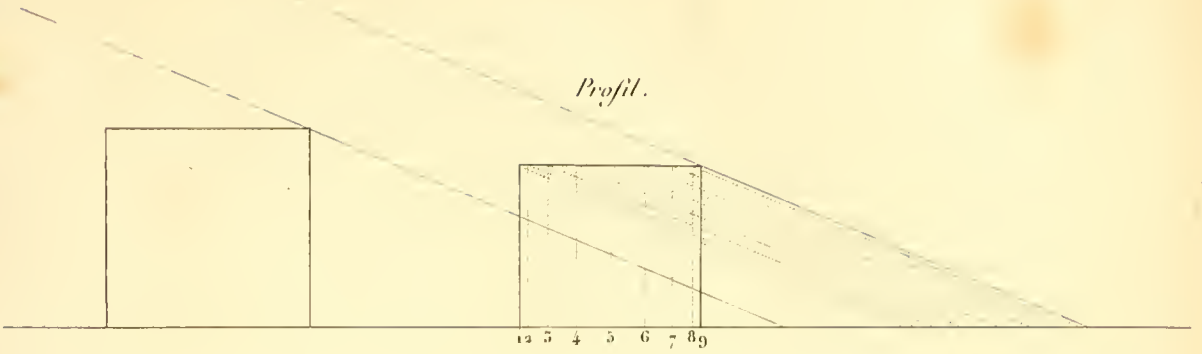

Plan.

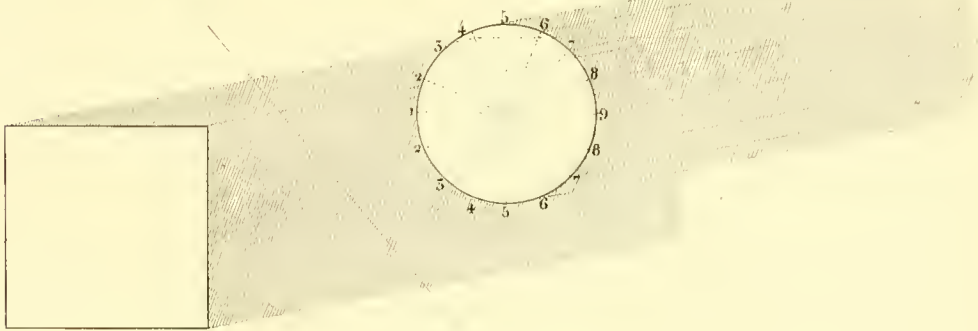

Elévation.



481 bis.

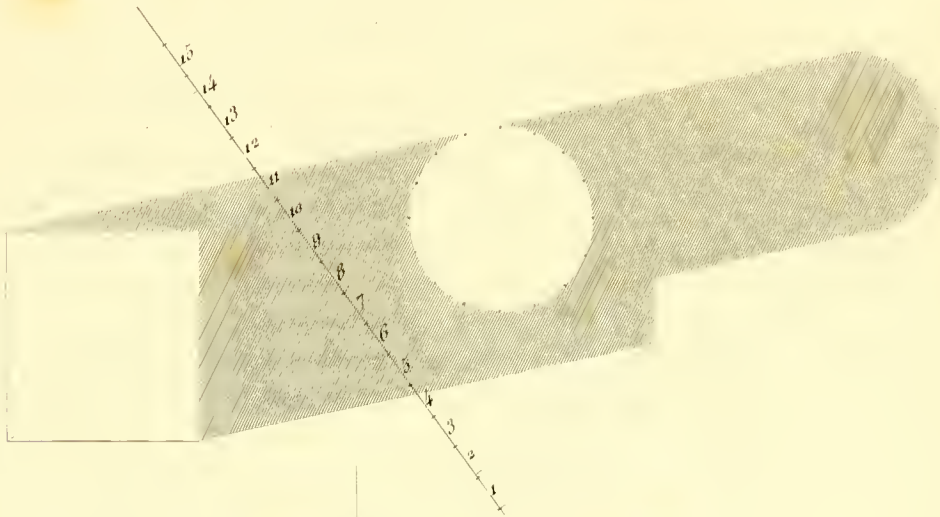
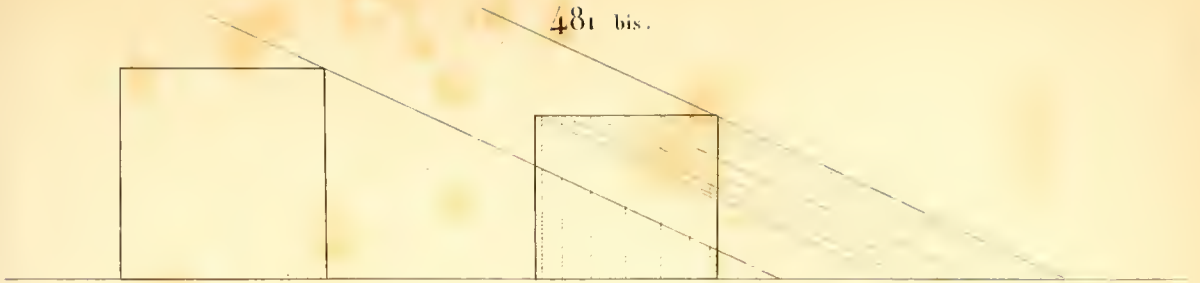

Élévation Perspective.

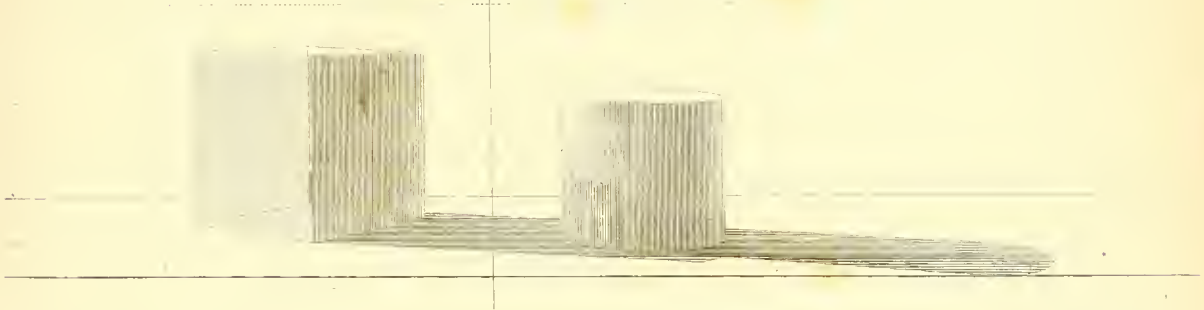

$\epsilon_2 D$

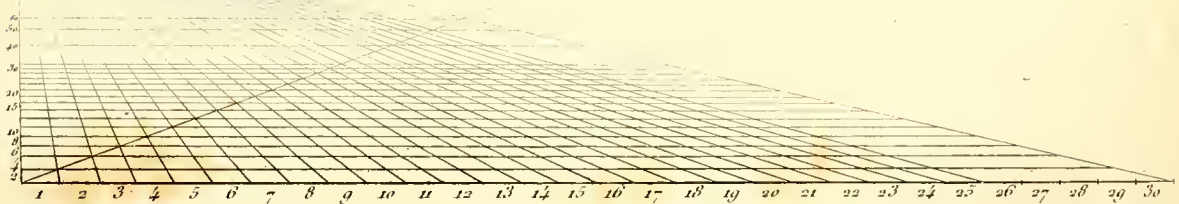

Dessiné par C. Chollot.

Gravé par J. Allais.



482.

Profil.

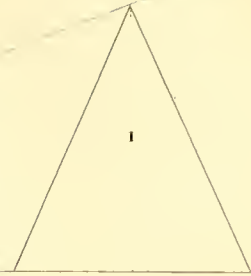
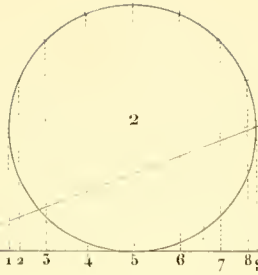

Plan.

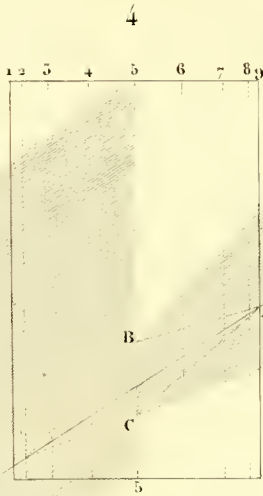

Elevation.

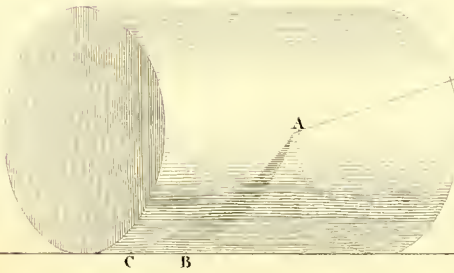

Profil.

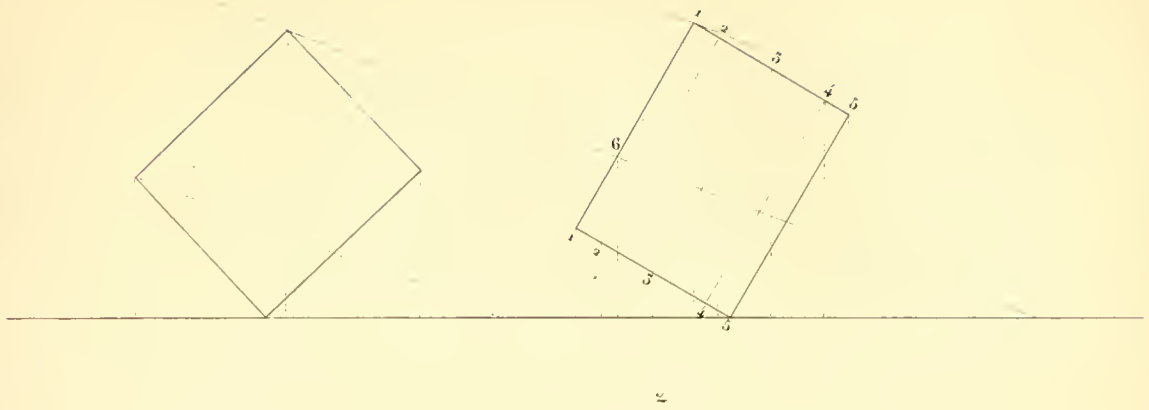

Plan.

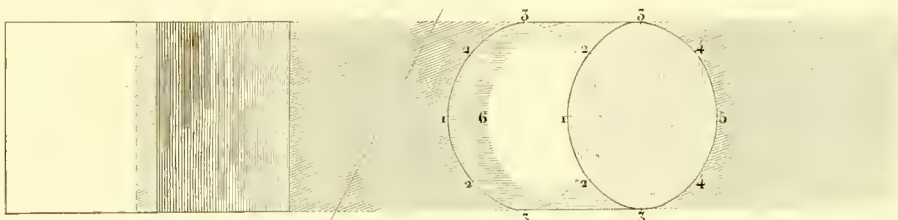

Elevation.

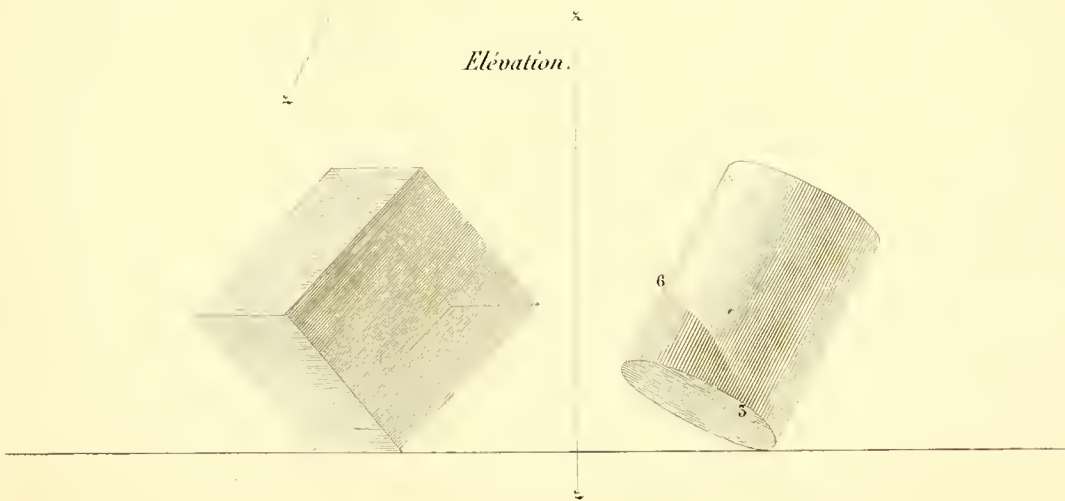

484.

Profil.

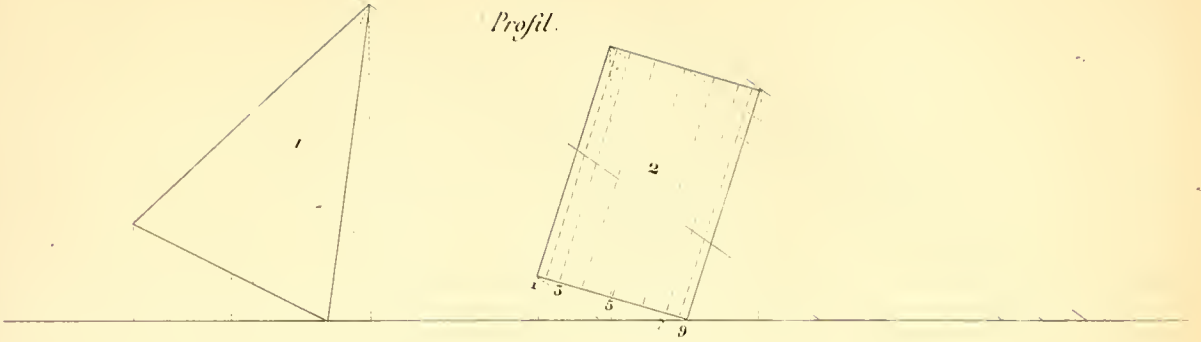

Plan.

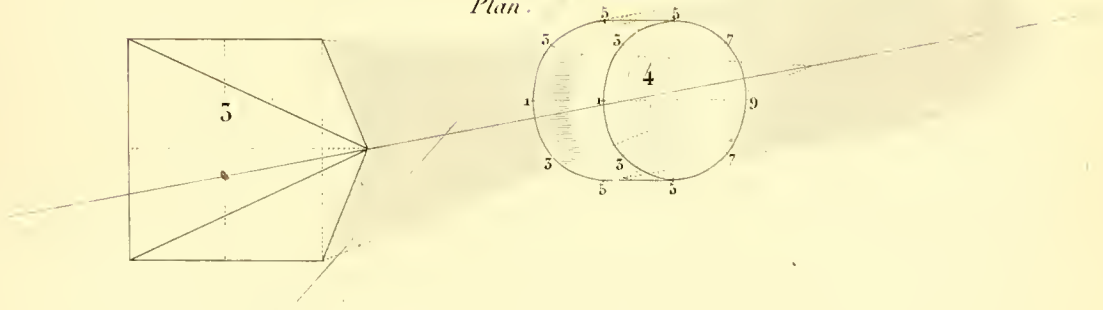

Elevation.

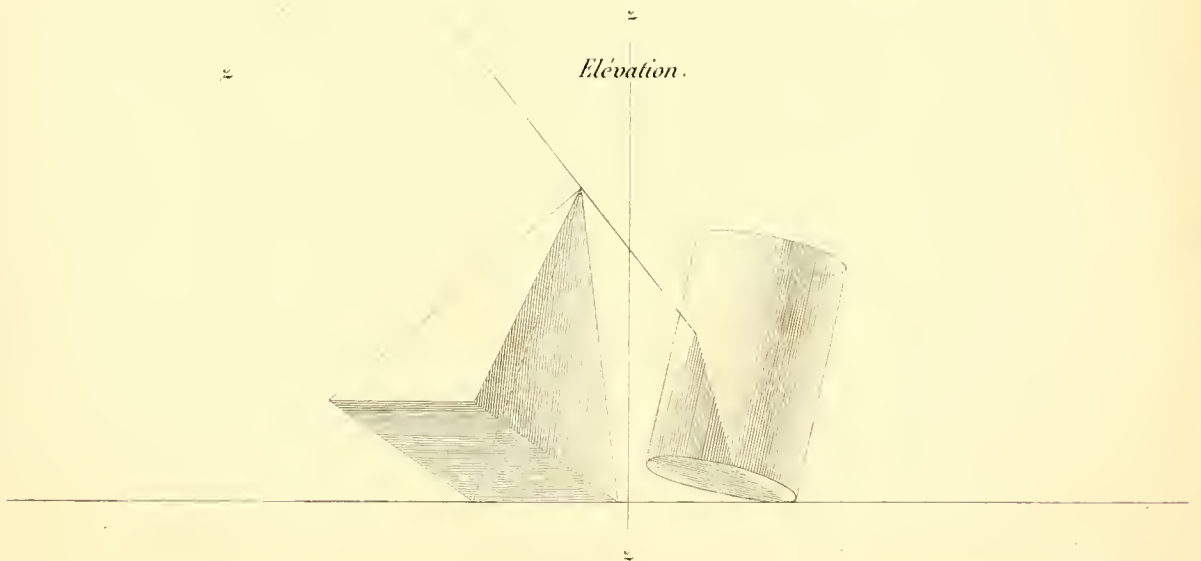

485.
Profil

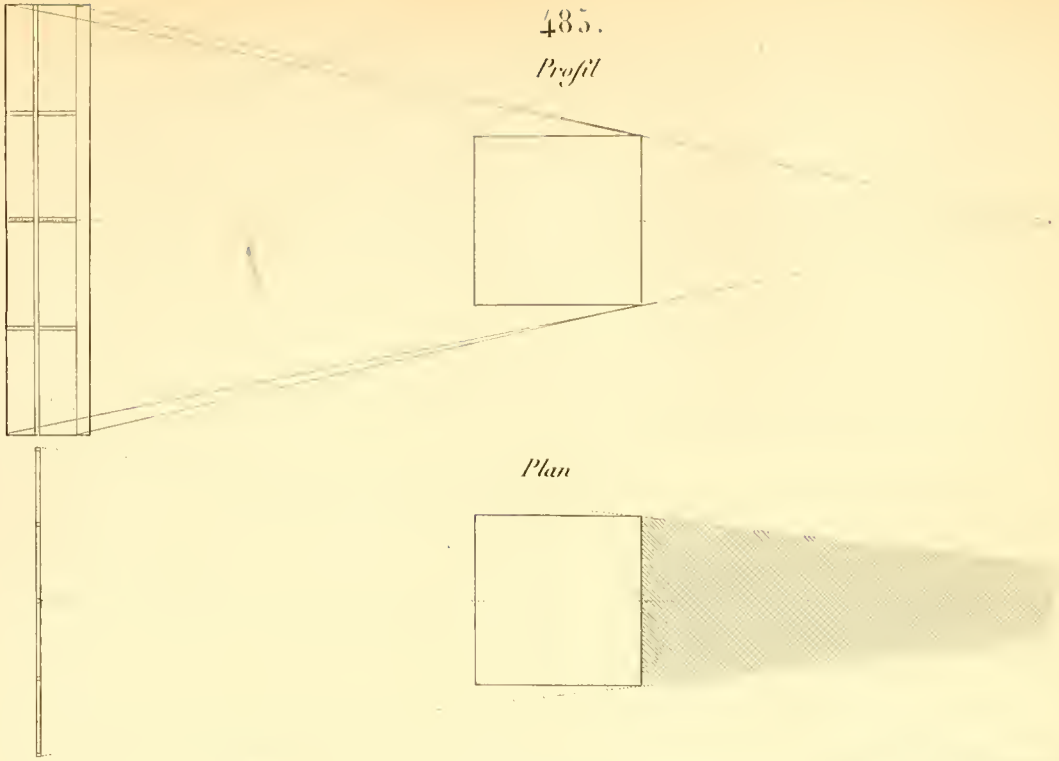

Plan



486.

Profil

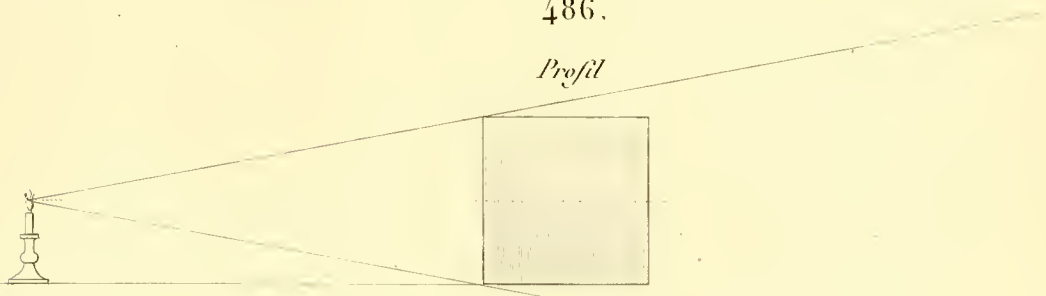

Plan

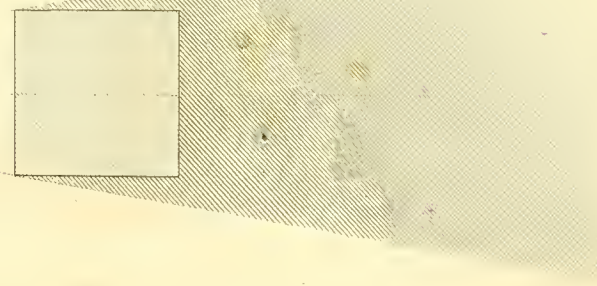

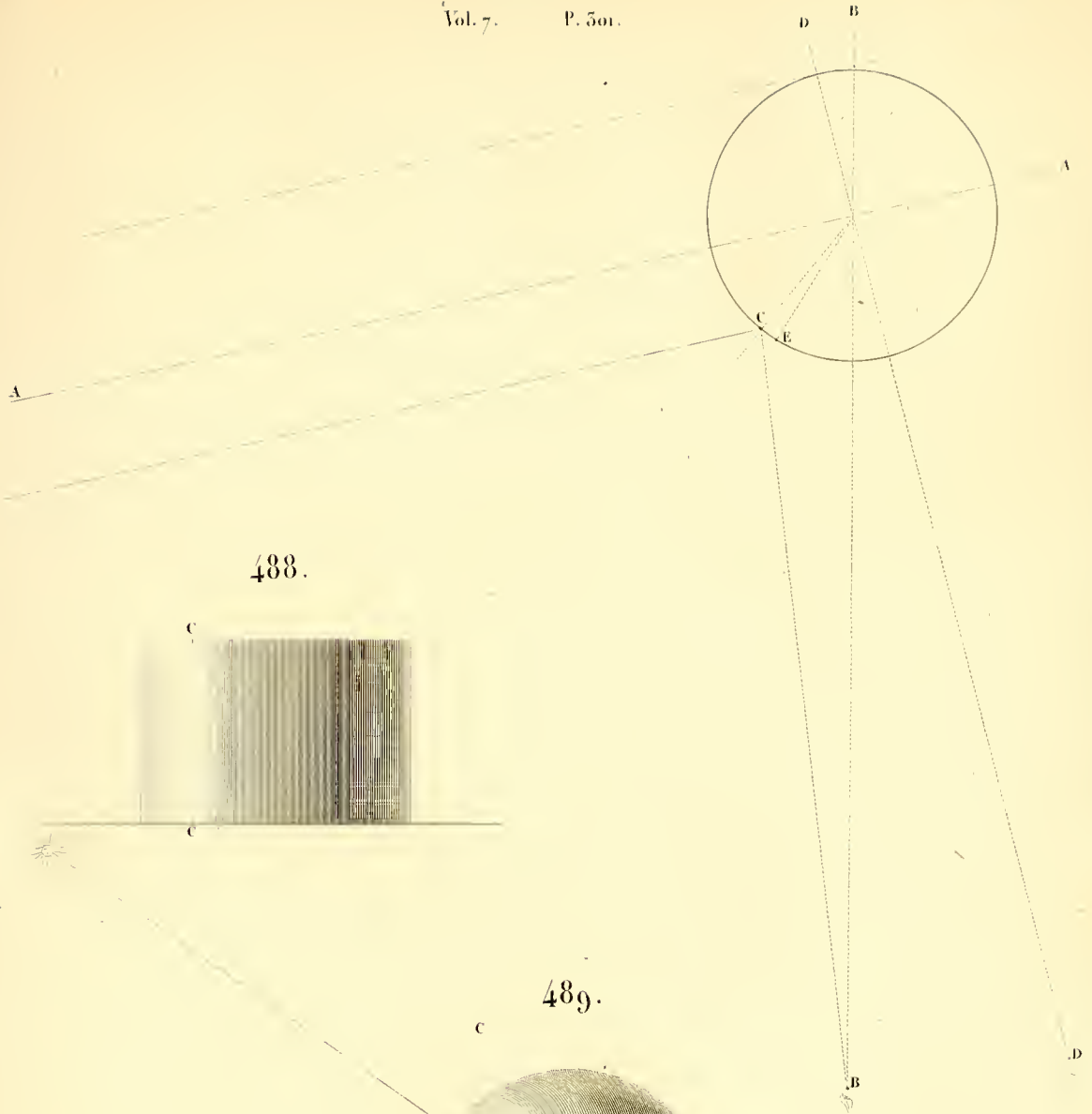

488.

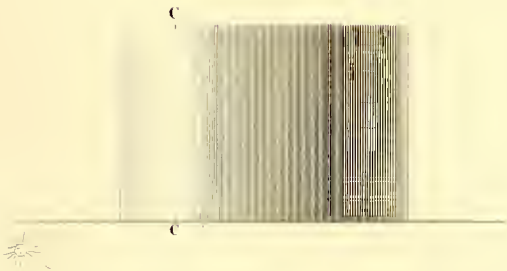

489.

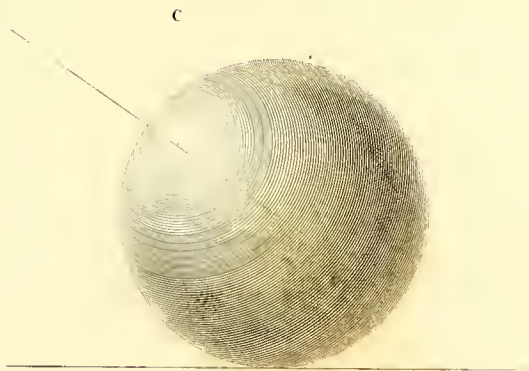



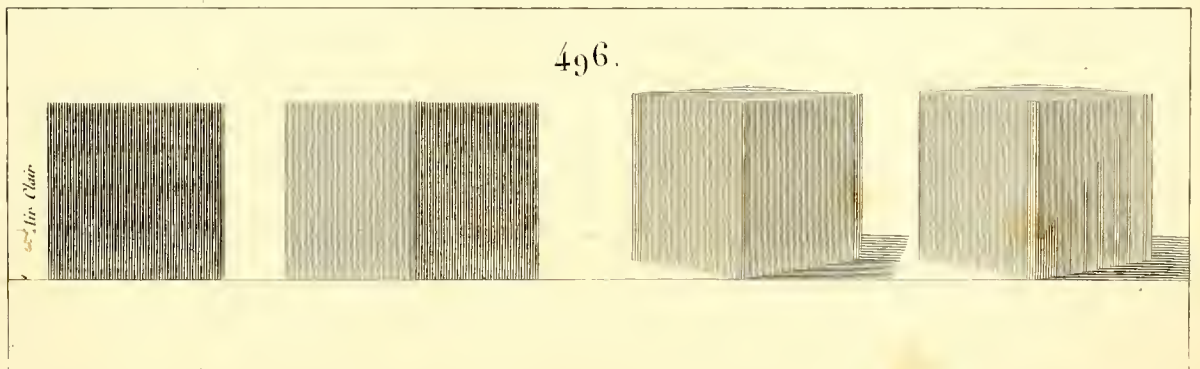
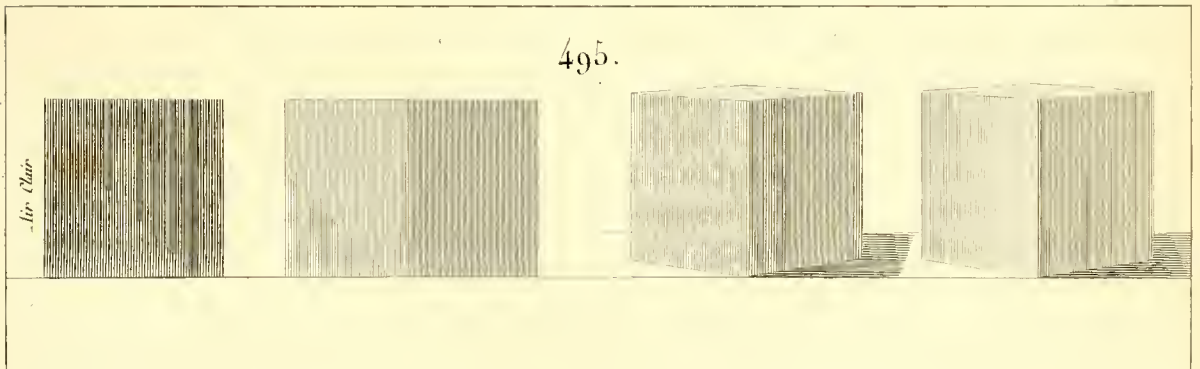
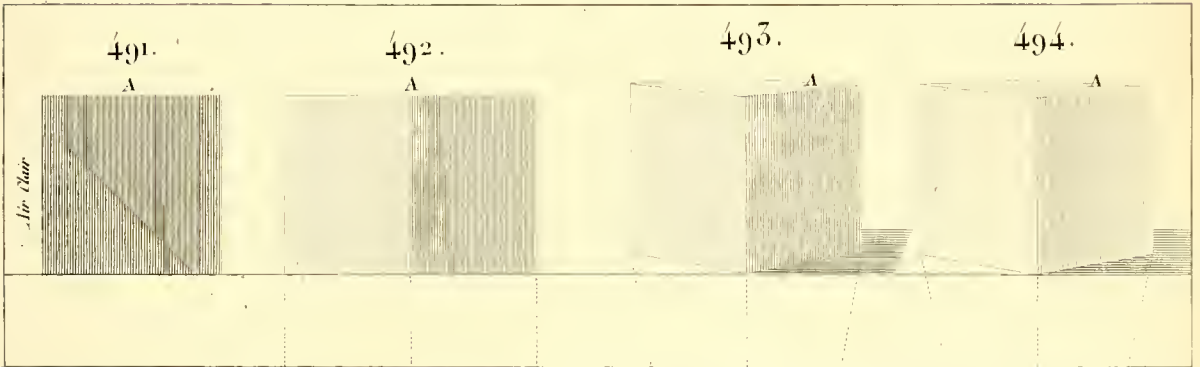
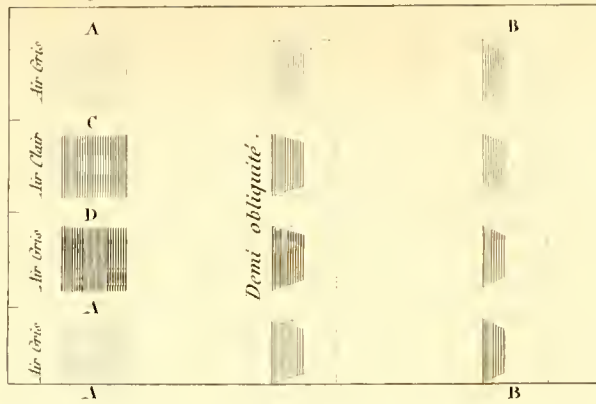



497.

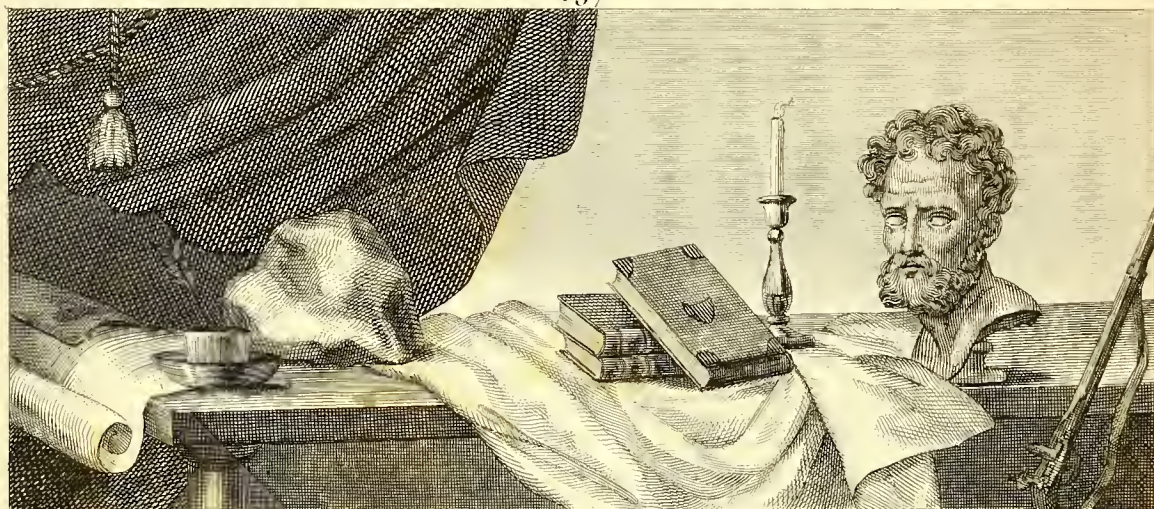

499.

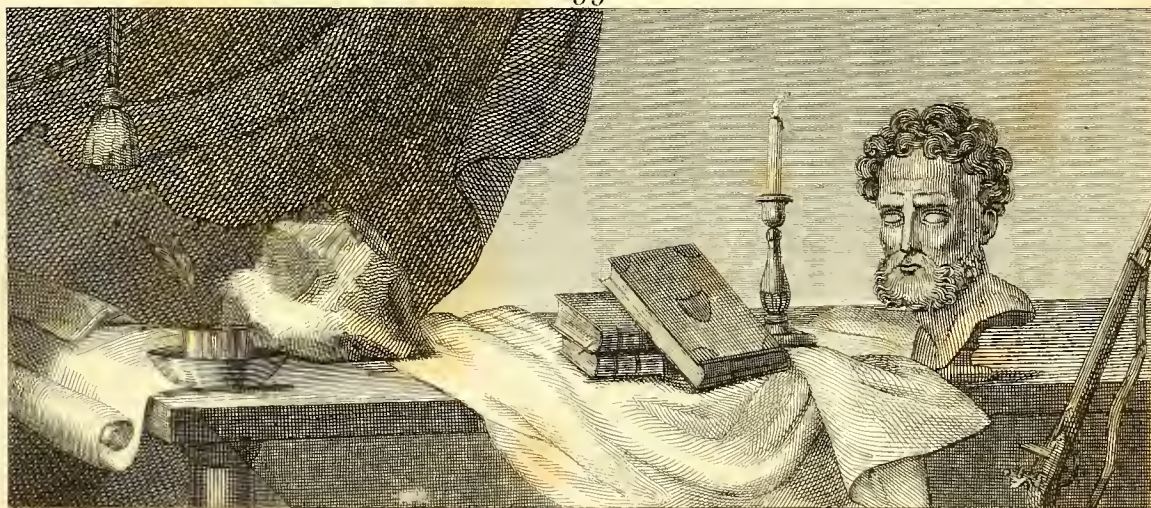

501.

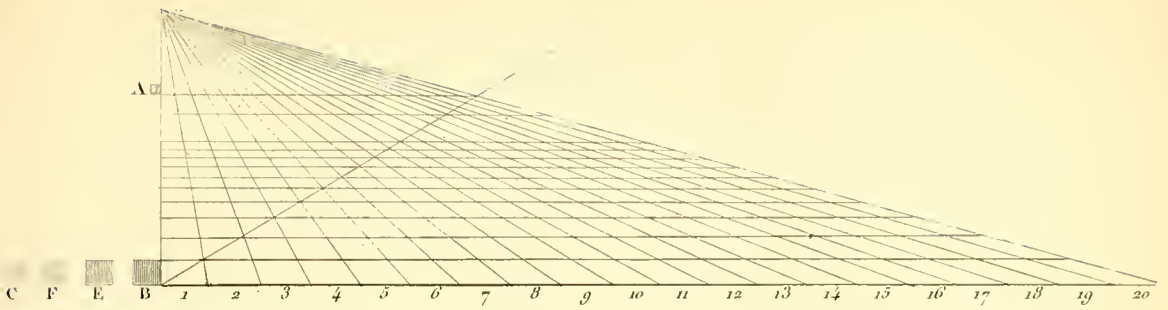

502.

D

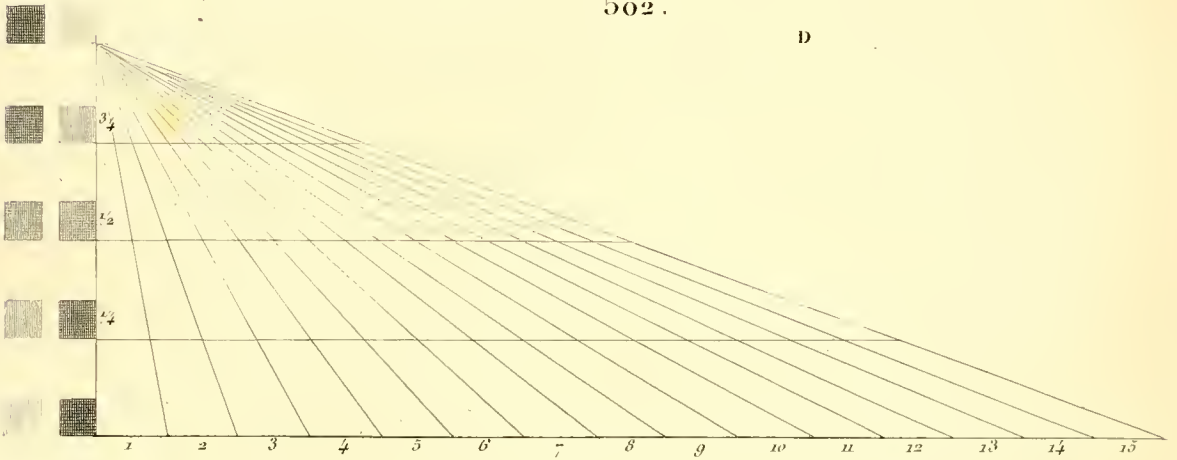

Application de l'Echelle Perspective.



500.



Vol 7. P. 509



Vol. 7.

P. 521.

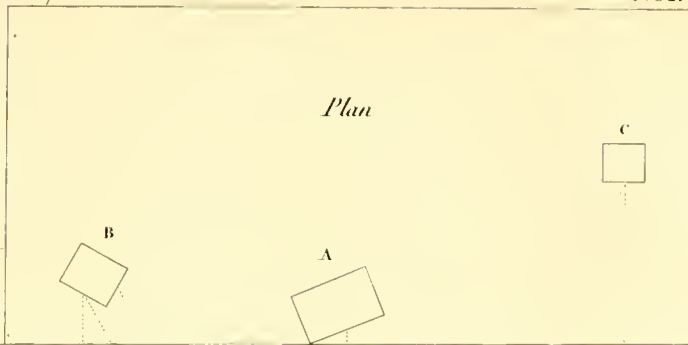

Vol. 7.

P. 525.

504.



Vol. 7.

P. 524.

505.

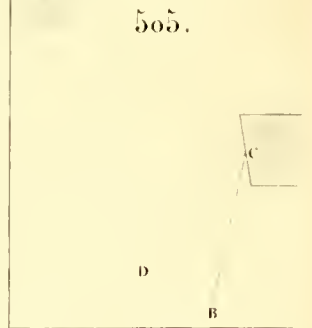

E

D

F

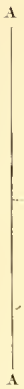

Vol. 7.



506.



P. 554.

507.

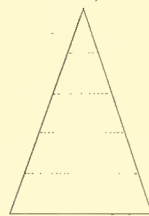

508.

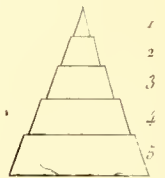

509.



511.



Vol. 7.

P. 347.

1

2

3

4

5

6

7

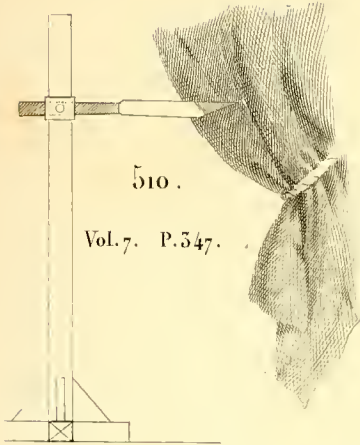

510.

Vol. 7. P. 347.

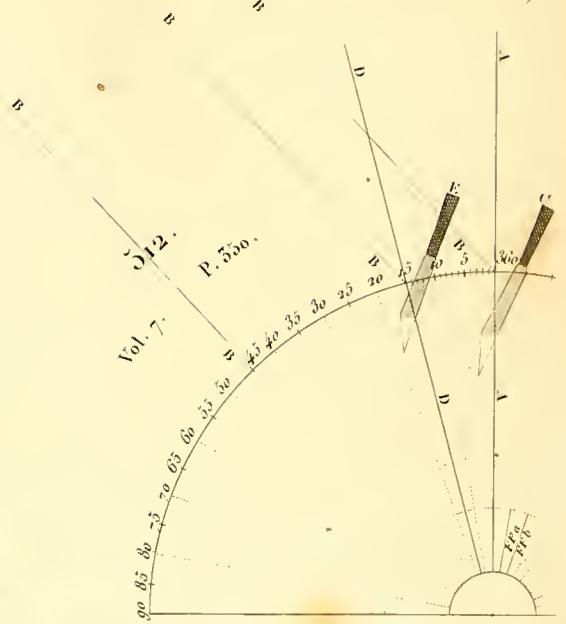

Vol. 7.

P. 350.

513.



I



I



Vol. 7.

514.

P. 380.

Jaune

Rouge

Bleu

Tons

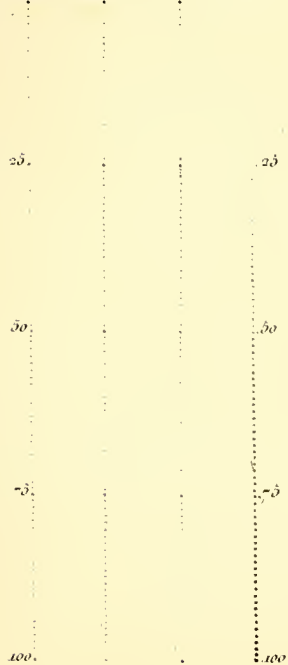

515.

Vol. 7.

386.



Vol. 8.

516.

P. 62.



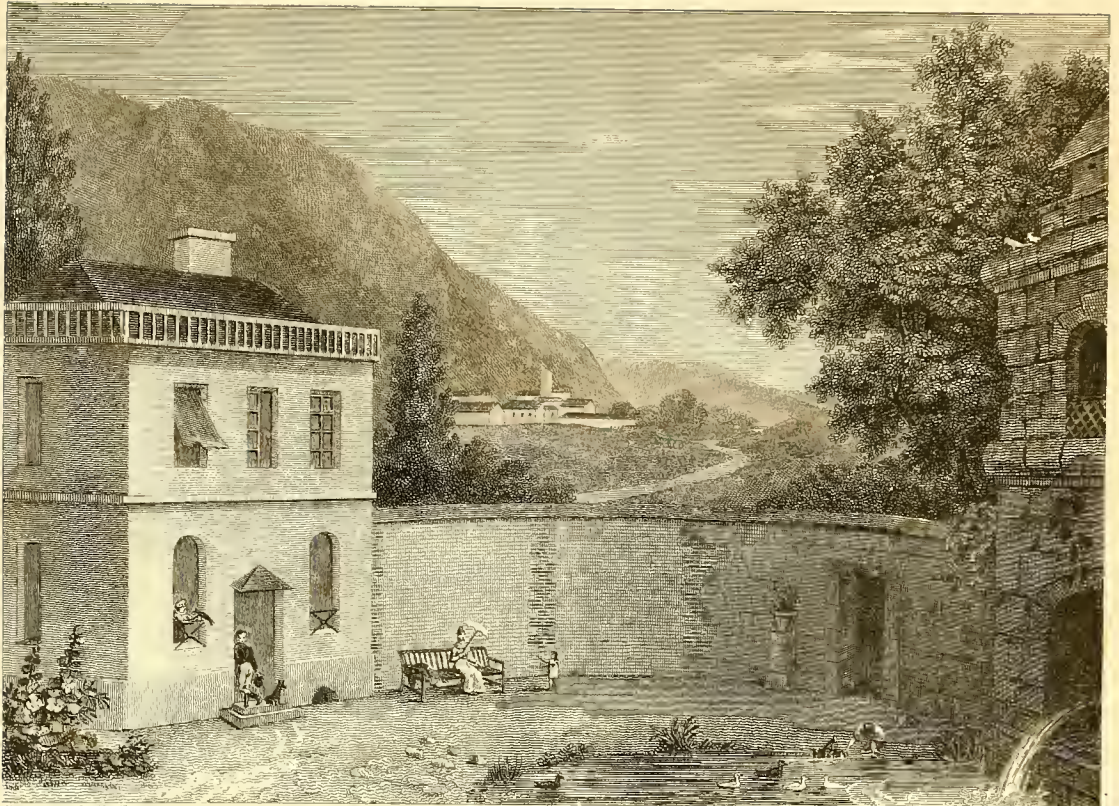

Peint par C. Chollot.

Gravé par J. Adam.



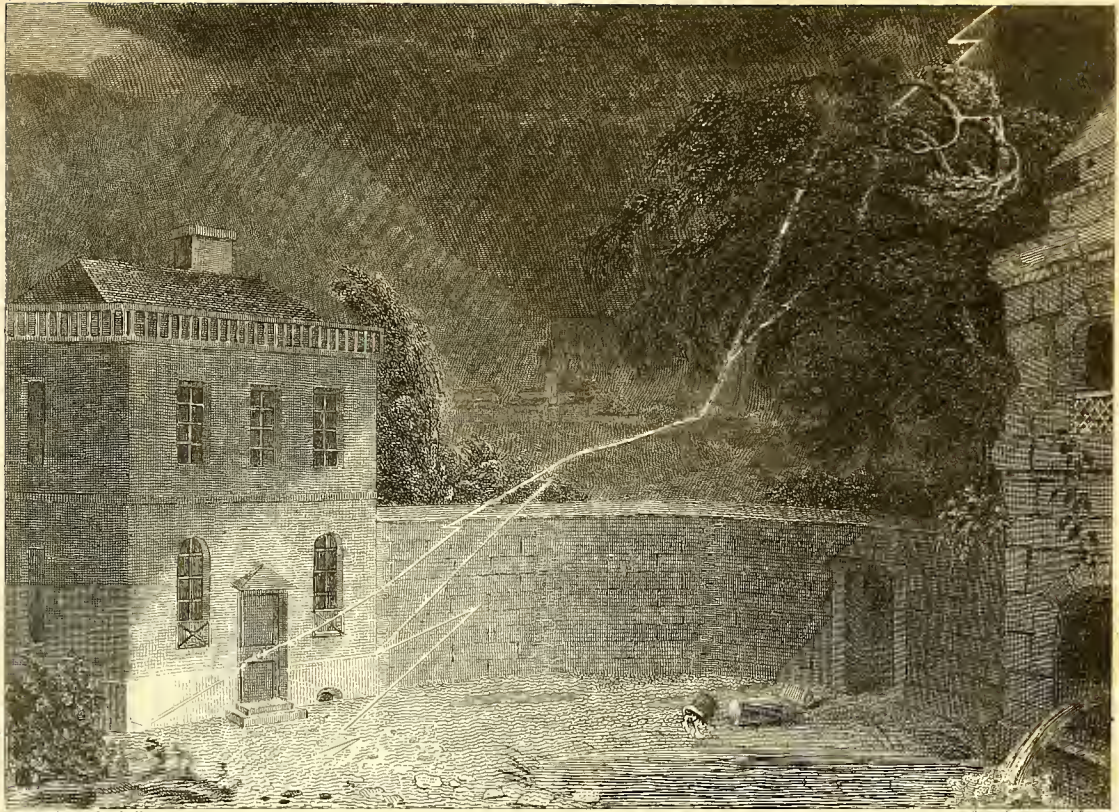

Dessiné par C. Chollot.

Gravé par J. Adam.

Fig. 518.

Pl. 106.

Vol. 8. P. 151.



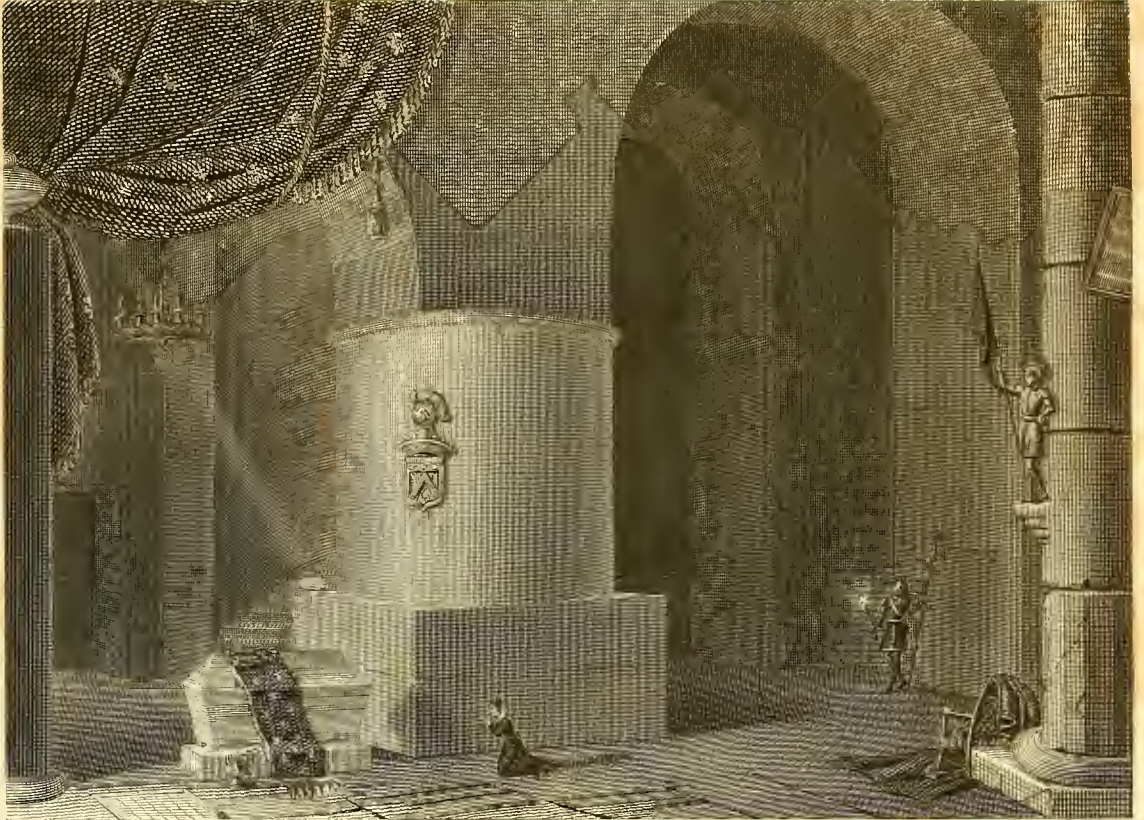

Peint par C. Chollot.

Gravé par J. Adam.

Fig. 519.



Gravé par J. A. Allais.

Pl. 108.

Fig. 520.

Vol. 8. P. 154 et 272.





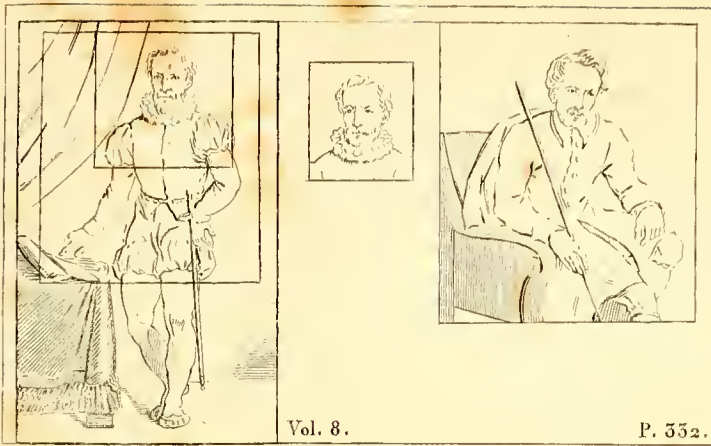

Vol. 8.

P. 332.

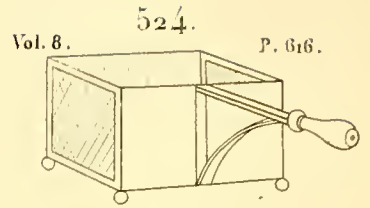

Vol. 8.

524.

P. 616.

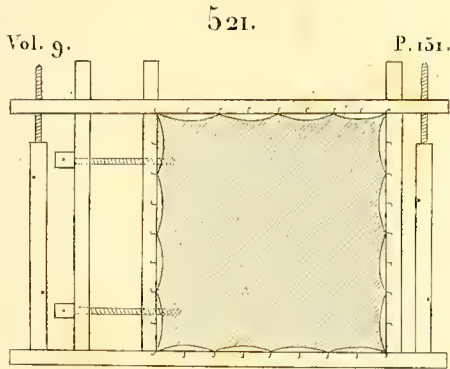

Vol. 9.

521.

P. 151.

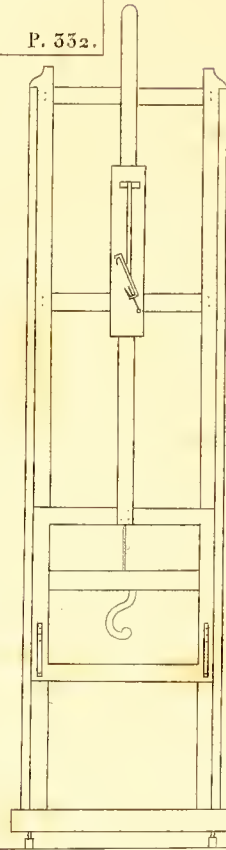

525.

Vol. 9.
P. 608.

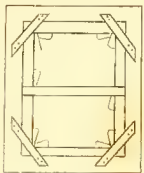
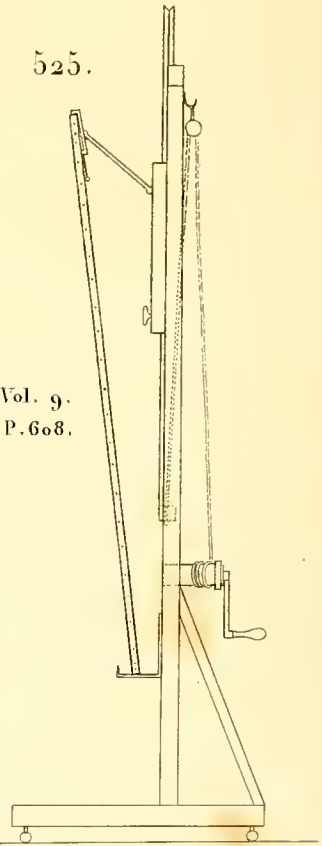

Vol. 9.
P. 602.

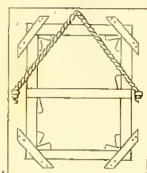

522.

525.

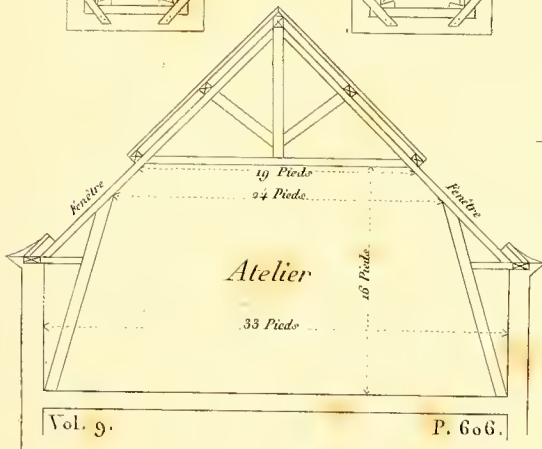

Vol. 9.

P. 606.

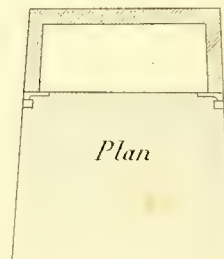

Plan

8 Pieds



526.

Vol. 9.

P. 641.

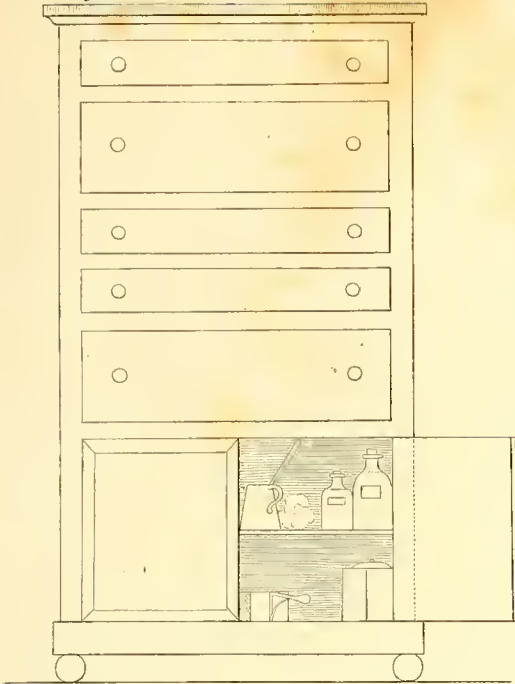

Vol. 9.

P. 651.

527.

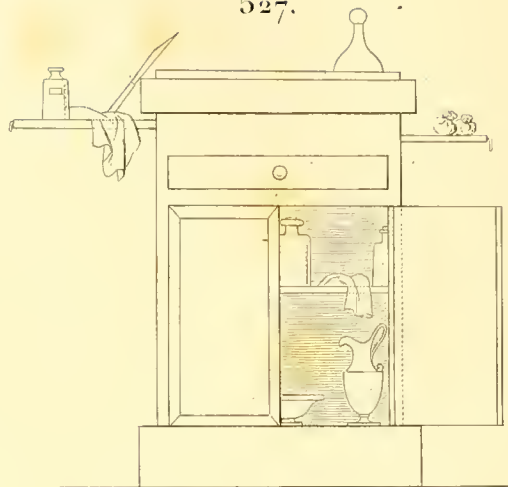
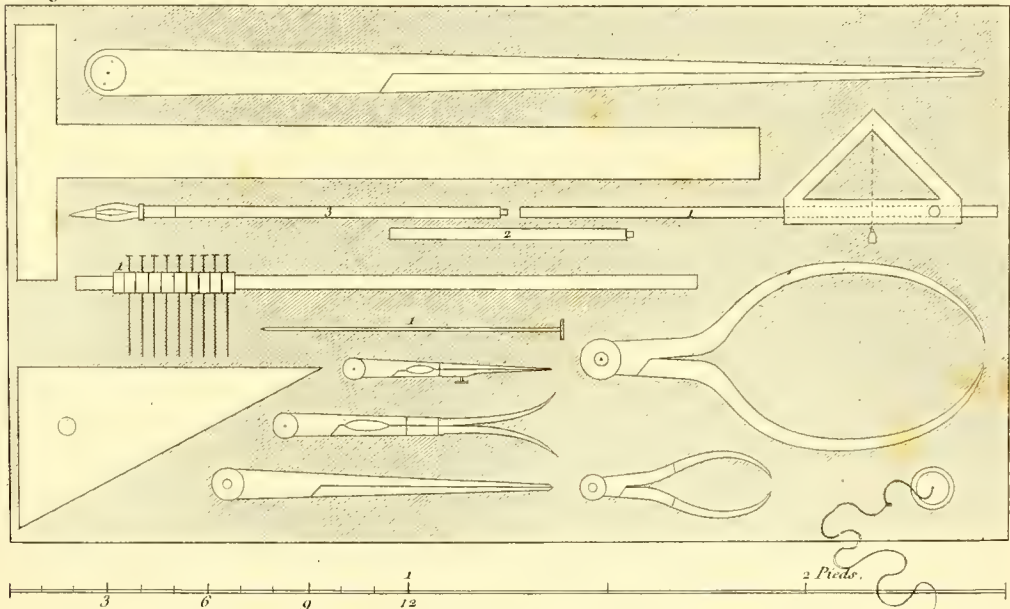

Fig. 528. et dernière.

Vol. 9.

P. 611.



FIN.



BOSTON PUBLIC LIBRARY



3 9999 05496 726 8

MAR 26 1981

